



Digital mixer

Reference manual

TF-12



DIGITAL LIVE SOUND CONSOLE

Applicable to: Firmware Version 2.0





TF-12
Mixer Reference





**Before installation, operation and maintenance of this product,
Please make sure to firstly read the [Important Safety Information]
on page I of this Manual.**

Revision history



Revision	Revision description and content updated
V1.0	Initial version
V2.0	Official version





Symbols used in this Manual

The following symbols are used for explanations on limiting, warning and prompt in operation and instructions so as to ensure safety:

	The purpose of the exclamation mark in an equilateral triangle is to remind the user of paying attention to the important safety, operation and maintenance instructions existing in the Manual.
	The arrow headed lightning symbol in the triangle is to remind the user of the un-insulated "dangerous" voltage that exists in the product housing and may constitute an electric shock risk to the human body.

" **Warning!** " is the term denoting the instructions on relevant personal safety. Failure to follow these instructions may result in personal casualty.

" **Caution!** " is the term denoting the instructions on damages that may be caused to the relevant devices. Failure to follow these instructions may result in equipment damage and this damage is not within the range of quality guarantee.



Important Safety Information

- In order to prevent fire or electric shock, please do not expose this equipment in the rain or a damp environment. The max. working environmental temperature is 40 °C, please do not insert power source in the unwatched condition. Please make sure to pull out the power plug immediately after completing the use.
- Please do not use the power source with the voltage and frequency not in conformity with those indicated on the machine, use of different ones may cause a fire or an electric shock.
- Please do not scrape, damage or alter the power cord nor place any heavy objects on the power cord, do not pull or over-bend the power cord.
- Lay the power cord at places far away from the heat, or otherwise the skin of the power cord will be softened and may cause a fire or an electric shock.
- Please do not use the power cord whose electric contact at any of its ends is found with the sign of corrosion or overheat, nor any power cord that it seems damaged in any way, as the damaged power cord may cause a fire or an electric shock.
- Make sure to use the power supply, outlet and power cord with protective grounding, so as to maintain the equipment in good protective grounding.
- Immediately turn off the power switch and unplug the power plug from the receptacle when the machine falls off or gets damaged in any way.
- Please do not make bold to open the cabinet and repair or reconstruct the machine, the high voltage and sharp components inside the machine may hurt you.
- Clean the machine with a piece of wiping cloth dipped with mild detergent and water and fully dried. Please do not use alcohol, paint thinner or other inflammable substances such as gasoline, nitrocellulose lacquer thinner etc.





Repair and Maintenance

This equipment belongs to precision electronic products, requiring a special maintenance and repair method. In order to avoid equipment spoilage, personal injury and /or add potential safety hazards, all the maintenance and repair of the equipment must be undertaken by the authorized service station or distributor. Our company will not take any liability for any hurt, impairment or mutilation caused by unauthorized repair conducted by the equipment client, owner or user.

FCC statement



Note: This machine conforms to the limitation for digital equipment of Category B as specified in Part 15 of FCC Rules after testing.

These limitations are specified for providing rational protection, preventing any harmful interference caused to the dwelling house facilities. This machine will produce, use and radiate radio frequency energy, failure to follow the directions for installation and operation of the machine may cause harmful interference to the telecommunication. But anyhow, we can not eliminate the possibility of any interference generated in special installation conditions. If the machine indeed brings harmful interference to radio or television reception (can be determined by turn on or turn off the machine), users are encouraged to try one or more of the following measures to rectify this interference:

- Change the orientation of the receiving antenna or resetting.
- Increase the distance between the equipment and the receiver.
- Separate the power outlet used by the equipment and the receptacle used by the receiver.
- Consult the dealer or experienced radio or TV technician for help.

RoHS Statement

This digital mixer complies with the 2011/65/EU Command on Restriction of the Use of Certain Hazardous Substances in Electrical and Electronic Equipment (RoHS).

This digital mixer complies with "China RoHS" standard. The table below is suitable for the products used in China and other regions:

Name of Components	Toxic or hazardous Substances and Elements					
	Pb	Hg	Cd	Cr (VI)	PBB	PBDE
PCB Assemblies	×	○	○	○	○	○
Chassis Assemblies	×	○	○	○	○	○

○: Indicates that this toxic or hazardous substance contained in all of the homogeneous materials for this part is below the limit requirement in SJ/T11363_2006.
 ×: Indicates that this toxic or hazardous substance contained in at least one of the homogeneous materials used for this part is above the limit requirement in SJ/T11363_2006.





Packing content of TF-12 Mixer



TF-12 Main Unit
(Not including tablet) 1pcs



AC power cord 1pcs



Bluetooth adapter
(USB interface) 1pcs



User's
reference manual 1pcs



Content

Symbols used in this Manual	I
Important Safety Information	I
Repair and Maintenance	II
FCC Statement	II
RoHS Statement	II
Packing content of TF-12 Mixer	III

Chapter 1 TF-12 Quick Start	1
1.1. Registration and upgrade	1
1.2. About the TF-12 mixer	1
1.2.1. Main features	2
1.2.2. Introduction of front panel functions	4
1.2.3. Introduction of rear panel functions	6
1.3. Tip wizard for quick start	7
1.4. Recall a preset scene and easily restore the required working parameters	8
1.5. Use Presets to tune	8

Chapter 2 Detailed Description of TF-12	9
2.1. Input Channels	9
2.1.1. Home of the input channels	9
2.1.2. Configuration	10
2.1.3. Gate	11
2.1.4. Parametric equalization (PEQ)	12
2.1.5. Compressor	13
2.1.6. Copy to	14
2.1.7. Preset	15
2.2. Output Channels	16
2.2.1. Home of the output channels	16
2.2.2. Configuration	17
2.2.3. PEQ (Same as the input channel, please refer to section 2.1.4)	17
2.2.4. Compressor (Same as the input channel, please refer to section 2.1.5)	17
2.2.5. Copy to (Same as the input channel, please refer to section 2.1.6)	17
2.2.6. Preset (Same as the input channel, please refer to section 2.1.7)	17
2.2.7. Main L/R channel setup	18
2.3. Route assignment operation	19
2.4. Effect processor	21
2.4.1. Signal Chain of FX	21
2.4.2. Add effect	21
2.4.3. Echo effect	22
2.4.4. Reverb effect	22





Content (continued)

2.4.5. Flanger effect	23
2.4.6. Stereo Delay effect	23
2.4.7. Quick selection of effects	24
2.5. Recording and playback with USB or PC sound card	25
2.5.1. USB playback	25
2.5.2. USB recording	26
2.5.3. Bluetooth playback	27
2.5.4. PC sound card recording and playback	28
2.6. Overview of the function map	29
2.7. System settings	30
2.7.1. SCENES	31
2.7.2. Automatic microphone mixing control (AMMC)	32
2.7.3. Acoustic feedback howling suppression (AFHS)	33
2.7.4. Settings and system information	34
2.7.4.1. Firmware Upgrade	34
2.7.4.2. Device Information & Network settings	35
2.8. APP connection and usage guidelines	35
2.9. Programmable central control remote operation	36
2.10. Control through interface RS-485	37
2.10.1. Connecting the central control equipment	37
2.10.2. Connect 86 boxes of wallboard controllers	37
Appendix 1. Technical performance parameters	39
Appendix 2. The Mixer Block Diagram	41
Appendix 3. Dimensions	42
Appendix 4. Operating guidelines for wireless MIC (optional purchase)	43





Chapter 1 TF-12 Quick Start



Notice: This manual is applicable to TF-12 digital mixer of firmware version 2.0. The old version is unable to support the full functions below, partial functions may have some difference. Firmware of higher version may have the manual of corresponding new version, please acquire the latest information in time.

1.1. Registration and upgrade

Before using TF-12 digital mixer, please take some minutes to visit website and register your TF-12 mixer. After completing registration, you can:

- Download the latest available firmware version of TF-12, install The latest functions for your mixer, or optimize and upgrade the performance.
- Timely receive the latest update notice.
- Obtain the relevant member favorable convenience, understand about the latest product pulse and the support you will probably obtain.

You can also obtain the related application knowledge and technique, find out video and other tools to help you easily and pleasantly use the TF-12 digital mixer.

1.2. About the TF-12 mixer

Professional field tuners often require four-band parametric frequency equalization (PEQ), high-pass filter (HPF), compressor (COMP) and noise gate (GATE) on each input. They often use more high-quality digital effect processors at the same time. On the output channel, they also need to conduct equalization, compressing and time-delay operation.

On the whole signal chain, the professional audio engineer has an endless pursuance for high quality of audio signals, including the top low distortion pre-amplifiers, professional-grade digital to analog / digital converter at input and output ends. TF-12 digital mixer provides you with professional, gliding and perfect performance. The simple and powerful PRESET & SCENES function can easily save or recall optimized parameter configurations.



Adaptive acoustic feedback and howling suppression function (AFHS) and automatic mixing function (AMMC) will become very simple and intelligent to use in meeting occasions.

From now on, you can experience the professional tuning fun easily and contentedly.





1.2.1. Main features

- With the digital signal processors (DSP) of the third-generation (SIMD core), precise 266MHz / 40bit floating-point mathematical operation, 24bit/48KHz high performance ADC/DAC, Concerned about the details of the sound you care about, showing a rich sound content.
- TF-12 digital mixer is configured with:
 - Input (12ch)** of 8-channels Mic / Line analog pre-processing (XLR female plug and 1/4" TRS input interface), 1 stereo Line-In channels, 1 stereo USB Media channel (U disk playback or Bluetooth audio) or PC sound card playback.
 - Output (10ch)** of 4 channels AUX, 1 stereo channel Main L / R (*Both are XLR male plug interfaces, differential balanced output circuits*)
1 stereo channel USB recording or PC sound card recording, 1 stereo headphone channel.
- All Mic / Line input channels are made of high quality professional grade microphone pre-amplifier: high dynamic, low distortion, that easily meet your requirements, to achieve good signal matching.
- Mic / Line input channels are configured with 48V Phantom power supply, Polarity switching (Pol.), Noise gate (Gate), Compressor (Comp)
4-band parametric frequency Equalizer (PEQ), high pass filter (HPF), low pass filter (LPF).
- All output channels are configured with Delay, Compressor (Comp), 4-band parametric frequency Equalizer (PEQ), high pass filter (HPF), low pass filter (LPF).
- Configuration professional DSP effectors (FX), 5 effect types: Echo, Reverb, Echo+Reverb, Flanger, Stereo Delay, totally over one hundred types of effect preset.
- Use the functions such as wizards, message indicators and [Scenes] / [Presets] / [Copy to] help users easily complete channel configuration, gain settings, and effect selection. [User Scenes] and [Presets] can be stored or recalled from the internal or external USB disk.
- With light entity touch switch and intelligent servo electric fader, give you the experience of smooth hand feeling. More visual and quick control is obtained with the color capacitive touch screen, user graphic operations interface combined with hardware physical buttons.
- Perfect switch "pop" sound automatic elimination function in the full voltage range (100Vac ~ 240Vac), than no annoying switch impact sound .Even if there is no sequential power controller, it will not affect your normal use.
- USB Media playback, support MP3, AAC, WAV, AIFF, APE or FLAC file format. Direct use of external USB disk recording.
- USB Bluetooth interface, plug and play, connect to your phone's Bluetooth device at any time to achieve wireless music playback.
- High-fidelity PC sound card, 48KHz / 24bit, can record and play at the same time, and easily realize online live broadcast.
- The input channels CH01 and CH02 are equipped with a high impedance instrument input function. Digital control of high resistance/low resistance status switching can follow the scene switching without switching impact.
- Adaptive automatic mixing control system (AAMC), the input channels include CH01 ~ CH08 and ST-in, USB playback, PC sound card, etc., which can realize automatic control of the MICs or background music. Equipped with intelligent algorithms for weight distribution and gain sharing.





TF-12 Mixer Reference



- Powerful howling suppression function (AFHS), with adaptive dynamic suppression and 4-band notch suppression, can be controlled independently, flexible and efficient.
- The exclusive Overview global function link overview menu interface, the complete processing of the audio signal from input to output is clear at a glance, and the parameter setting can be performed by clicking the corresponding node.
- **ISUeasy™** remote firmware upgrade function supports comprehensive upgrade of the system by piloting the upgrade package data from the USB port (including MCU programs), ensuring that the mixer you purchased will be readily and completely upgraded to the latest state.
- TF-12 mixer provides LAN IP networking function, IOS iPad or android tablet can wirelessly connect to the mixer for remote control operation. APP software for wireless remote control of almost all parameters of the mixer.
- Programmable central control remote control, using the device's network port, this digital mixer can accept the remote control command of the center console. The communication protocol uses an easy-to-understand ASCII command language and a flexible and extensible syntax structure. RJ-45 network port or RS-485 port.
- RS-485 interface with 5V/500mA power supply can easily connect multiple 86 box wallboard controllers to achieve synchronous and fast control.
- Optional purchase function: built-in two-way wireless microphone receiving module, integrated design, long receiving distance, good sound, simple and practical.
- The routing of output buses AUX1 and AUX2 provides fully independent selection functions for Pre-Fader and Post-Fader. The input channel CH01~CH08 can achieve independent Pre-Fader and Post-Fader routing control.





1.2.2. Introduction of front panel functions

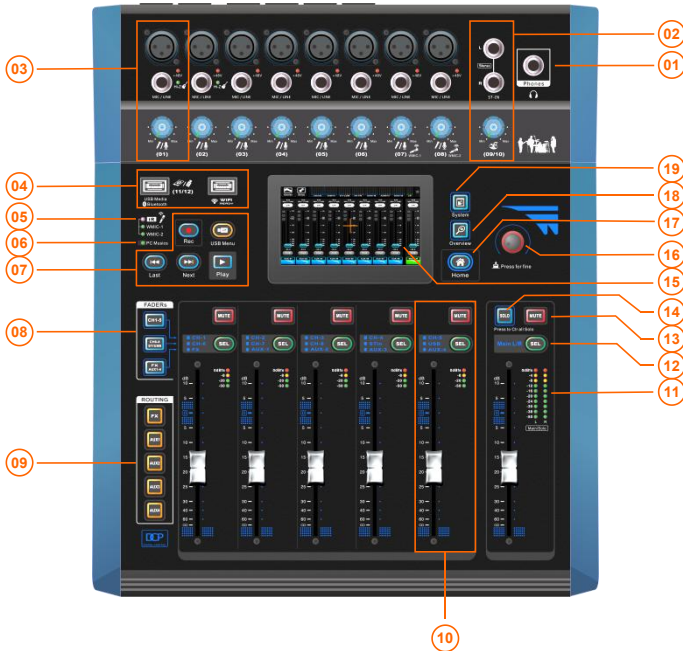





- 01 The monitor headphone output socket can directly drive stereo headphones.
- 02 Stereo line input and analog gain adjustment.
- 03 MIC/LINE input, XLR female plug and 1/4" TRS input interface are connected in parallel, please do not input at the same time! The red LED lights up when there is 48V phantom power output. When the Hi-Z indicator light is on, it is in the high impedance instrument input state. It is switched on the channel parameter menu of the main screen. Only CH01 and CH02 have this function. The potentiometer is used to adjust the analog gain of this channel to achieve the best signal input matching. Optional purchase function: If the wireless microphone WMIC1/WMIC2 is purchased, the potentiometers of CH07 and CH08 are also used to adjust the input gain of this wireless MIC.
- 04 USB interface, which can be connected to U disk to play, record, import and export files or upgrade system firmware. Can also be connected to a BT adapter .
- 05 Optional function: indication of wireless microphones WMIC1 and WMIC2. The light is off to indicate disconnection, the steady light indicates normal operation, and the blinking indicates that the wireless microphone is muted. IR light is used for wireless microphone pairing. For details, refer to Appendix 4.
- 06 PC sound card indicator, when it lights up, it indicates that the mixer is currently working in PC sound card mode.
Note : There are 3 modes for users to choose from: USB playback, Bluetooth playback, and PC sound card playback. This mixer can only work in one of these modes, which can be selected in the USB software menu.





TF-12 Mixer Reference



- 07 Quick USB operation buttons, including songs [Play]/[Record]/[Last]/[Next], etc. And click the button  to quickly enter the USB Media control menu.
- 08 Fader page button: [CH1-5] for the input channel CH1~ CH5 , [CH6-8/ST/USB] for the input channels CH6 ~ CH8, ST input, USB media playback , [FX /AUX1-4] for the effect FX and output channels AUX1~AUX4.
- 09 Button for routing bus selection. Click one of the buttons to enter the routing volume setting mode of this bus, and the corresponding routing bus button is blinking. At this time, select the button in , and the corresponding input channel can be used to set the routing send volume. [MUTE] button is used for routing mute. Click the flashing bus button again to exit the route setting state.
- 10 Channel control unit. [MUTE] is used to mute the channel. [SEL] is used to enter or exit the channel parameter editing menu. The LED indicator is used to indicate the level of this channel. Motorized faders are used to set channel volume or route volume.
- 11 Level indicator. When the [SOLO] button of  is lit and flashing, this level bar is the monitor level indicator, otherwise it is the Main L/R main output level indicator.
- 12 Main L/R main output channel selection button, click to enter or exit the channel parameter editing menu.
- 13 Main L/R output channel mute button.
- 14 [SOLO] Monitor switch button, click to switch. When the [SOLO] button is lit and flashing, the electric fader is used to adjust the volume of the monitor headphones, and the LED level bar is the monitor level indicator. When the [SOLO] indicator is off, the electric faders and level bars are for the Main L/R channel.
- 15 On the main display screen, you can click on the corresponding parameter and use the  main jog shuttle to adjust the parameters.
- 16 The main jog shuttle is used to adjust the parameters with the main screen. Press down to switch between coarse and fine adjustments.
- 17 [Home] shortcut button, click to quickly return to the Home page. The status of each channel can be viewed on the Home page.
- 18 Overview shortcut button, click to enter. In the Overview menu, you can quickly understand the state of the signal from input to output and signal processing. And can carry out parameter setting.
- 19 [System] Shortcut button for system parameter setting. Click to enter the system parameter setting menu.





1.2.3. Introduction of rear panel functions

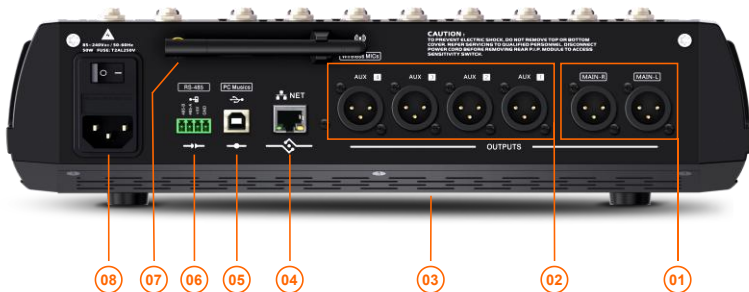

- 01 Main L/R output interface, differential balanced output, XLR male interface.
- 02 AUX1~AUX4 output interface, differential balanced output, XLR male interface.
- 03 The bottom of the machine is the exhaust vent of the fan, please do not block or cover it !!
- 04 RJ45 network control interface, used for central control or remote command transmission.
- 05 The USB interface of the PC sound card is used to connect to the computer to realize the virtual sound card function. (No need to install driver)
- 06 RS-485 interface, 5V power supply current consumption shall not be greater than 500mA. It can connect 86 boxes of wallboard controllers.

- 07 External antenna for wireless microphone WMIC. This antenna is only available after purchasing the wireless microphone assembly.
- 08 AC power input interface, fuse and power switch.

Warning : In order to ensure the safety of people and equipment, and to prevent the equipment from being disturbed and working unstable or damaged , three-core plugs, sockets and cables with protective grounding must be used, and safety grounding must be reliable !!

Must use a fuse that matches the specified specifications !!

- 01 Main L/R output interface, differential balanced output, XLR male interface.
- 02 AUX1~AUX4 output interface, differential balanced output, XLR male interface.
- 03 The bottom of the machine is the exhaust vent of the fan, please do not block or cover it !!
- 04 RJ45 network control interface, used for central control or remote command transmission.
- 05 The USB interface of the PC sound card is used to connect to the computer to realize the virtual sound card function. (No need to install driver)
- 06 External antenna for wireless microphone WMIC. This antenna is only available after purchasing the wireless microphone assembly.

- 07 AC power input interface, fuse and power switch.

Warning : In order to ensure the safety of people and equipment, and to prevent the equipment from being disturbed and working unstable or damaged , three-core plugs, sockets and cables with protective grounding must be used, and safety grounding must be reliable !!

Must use a fuse that matches the specified specifications !!





1.3. Tip wizard for quick start

You can have a quick start

- 1). Connect TF-12 mixer with Mics, Music instruments, amps etc.
- 2). Turn on the power of TF-12, wait for start of the unit, normally it will take around 25 seconds.

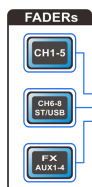

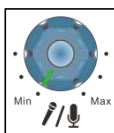

3). Select the corresponding fader page button according to the fader page where the input channel is located.





4). Adjust the analog gain of the relevant input channel (as shown on the left) and observe the channel level bar indicator until the green LED at position 0 lights up.



5). If you need to set the parameters of the corresponding channel, click the button  to enter the parameter setting menu. **Note:** *GATE, COMP and EQ/HPF/LPF function will probably effect the input level, or even lead to dramatically decay of input signal.*

6). Click the button  to cancel the mute setting of the corresponding input channel, push the fader  to the appropriate volume position, such as 0db.

7). Set up other input channels in the same way. Click the button  of other channels to switch to other channels for parameter setting, or use the [Copy to] function to quickly copy the parameters of the current channel to other similar channels.

8). By default, the input channel signal is automatically output from the Main L/R channel. Click the button  to cancel the mute setting of the Main L/R channel, Push the fader  to the appropriate volume position, and there should be sound output at this time.

9). If you choose the mixing output bus (AUX1 ~ AUX4, FX) as the output interface, please click the corresponding bus button (as shown in the right). The selected bus button flashes yellow light, and the mixer is in the routing setting state (in the APP, the name bar and navigation bar of the input channel that can be used as routing are marked in brown, and the fader slider is also marked in brown).



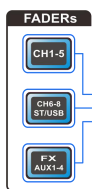

10). Select the corresponding fader page button according to the fader page where the input channel is located.

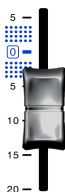

11). Click the mute button  to cancel the routing mute setting of the input channel, then adjust the routing volume of the channel.

12). The routing and sending of other input channels are set in the same way. The volume sending of the effect is also done in this routing setting.

13). Click the flashing route bus button again to exit the route setting mode.

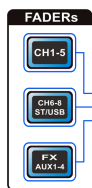

14). Click the fader page button  to select the output channel page.

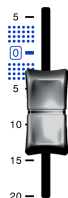

15). Click the button  to cancel the mute setting of the corresponding AUX output channel, then adjust the volume of the output channel. At this time, the corresponding AUX channel should have sound output.

16). If you need effect processing, follow the above steps 9) ~ 15) to set the routing input for the selected effect module (change the AUX to the operation FX).

17). Congratulations, the quick operation of the mixer is successful !! You can learn and master the use of TF-12 digital mixer in detail through the following chapters, and experience the joy of tuning !!

1.4. Recall a preset scene and easily restore the required working parameters

What is a scene? Scene are a group of settings saved in advance by manufacturer or by the user, and can be recalled at any time, and all the parameters of the TF-12 digital mixer can be set as the value of the scene. TF-12 digital mixer includes a lot of preset scenes to be used in all kinds of performance occasions. In allusion to the performance that you will tune for, you can find the most suitable scene. (Refer to Paragraph 2.7.1 for details)

1.5. Use Presets to tune

What is the preset? The channel preset is a group of multi-parameter settings saved and aimed at one channel, it can be recalled at any time. All the input channels/bus channels/effect channels of TF-12 digital mixer have the corresponding presets, the fussy parameter adjusting work is completely avoided, it is only required to save the adjusted parameters as presets, and recall it to restore the original operating state when it is used in the future.

The preset is suitable for MIC and musical instrument and is preset by the skilled and experienced audio engineer for performance application on site. The preset is very useful and has very good effect with less modification required, or no modification is required at all.(details refer to 2.1.7 / 2.2.6)





Chapter 2 Detailed Description of TF-12

This section details the screen and operational controls of the TF-12 digital mixer. The operation of this tuning station basically consists of input channel setting, bus output channel and routing settings, effect settings, and system settings.

2.1. Input Channels

2.1.1 Home of input channels



- 01 Noise gate symbol, when it is lit, it means that the noise gate function is on.
- 02 Compressor symbol, when lit, it means that the compressor function is on.
- 03 Channel volume fader.
- 04 Channel volume scale, unit db.
- 05 SOLO button.
- 06 Channel volume value, unit db.
- 07 Channel name, which can be modified in channel [CONFIG].
- 08 Channel control panel.

- 09 Main L/R output channel control panel.
- 10 Fader pages.
- 11 Channel volume adjustment.
- 12 Channel mute button.
- 13 Channel selection button, click to enter the channel setting menu, you can set the PEQ, noise gate, compressor, etc. Click this button again to exit the channel setting mode.
- 14 Channel level meter, unit dbu.
- 15 SOLO control switch button.

(Partial view of TF-12 mixer panel)

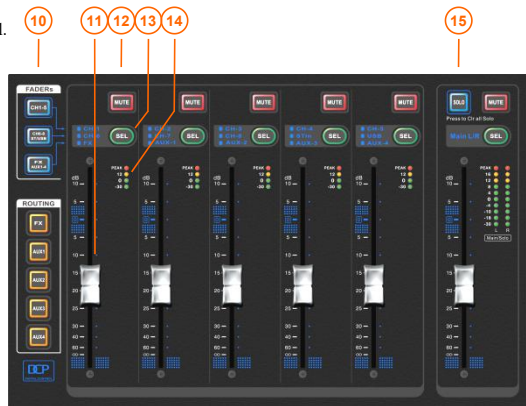



2.1.2 Configuration

The channel settings configure the channel name, analog gain, phantom power, pan balance, and more.

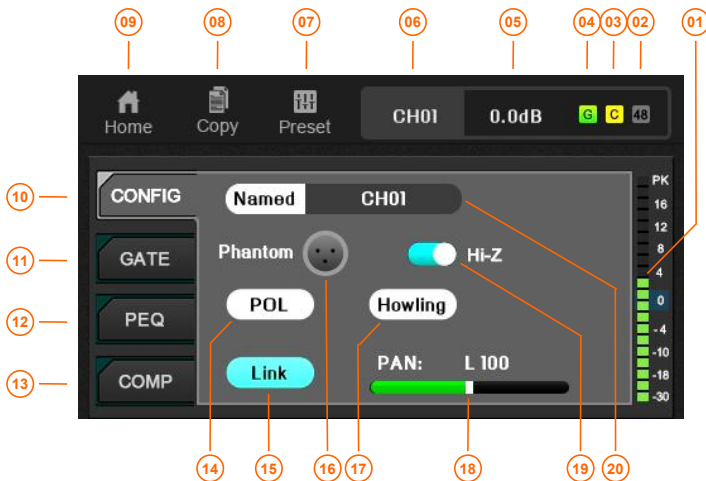

- | | | | |
|----|---|----|--|
| 01 | Channel level meter, used to measure the strength of the channel signal, in dbu. PK stands for +18dbu and above. | 02 | 48V phantom power symbol, when lit, it indicates that the 48V phantom power output is valid. |
| 03 | Compressor symbol, when lit, it indicates that the compressor is active. | 04 | The noise gate symbol, when it is lit, it indicates that the noise gate is effective. |
| 05 | Channel volume gain number, unit db. | 06 | Channel name. |
| 07 | Click to switch to the parameter preset page. | 08 | Click to switch to the parameter copy page. |
| 09 | Home button, click to return to the home page (channel overview menu) | 10 | Click to switch to the channel CONFIG page. |
| 11 | Click to switch to the noise gate page. | 12 | Click to switch to the PEQ page. |
| 13 | Click to switch to the Compressor page. | 14 | Polarity switch, when it is lit, it means negative polarity. Click this button to switch. |
| 15 | Link, the two adjacent MONO channels are linked into a pair of stereo channels.
<i>Only channel linking such as (CH01, CH02), (CH03, CH04), etc. are supported, and channel linkings such as (CH02, CH03), (CH04, CH05), etc. are not supported. The parameters of the odd channel are automatically copied to the even channel when linked, and the phantom power control is also copied.</i> | | |
| 16 | Phantom power switch. The +48V Phantom power is active when lit. | | |
| 17 | Add this channel to the howling suppression function when it is on. The setting of howling suppression function is carried out in the [System] menu. | | |
| 18 | Pan balance adjustment assigned to the Main L/R output channel. | | |
| 19 | High impedance input switching is used for musical instruments. Only CH01 and CH02 have this function. In case of high impedance input, the input shall not be suspended to avoid induced noise. | | |
| 20 | Channel name. The user can modify it, up to 6 English characters and numbers in length. Click this area to enter the channel naming page. | | |





2.1.3 Gate

The noise gate allows an audio signal above a set threshold to pass, attenuating or muting the audio below the threshold.

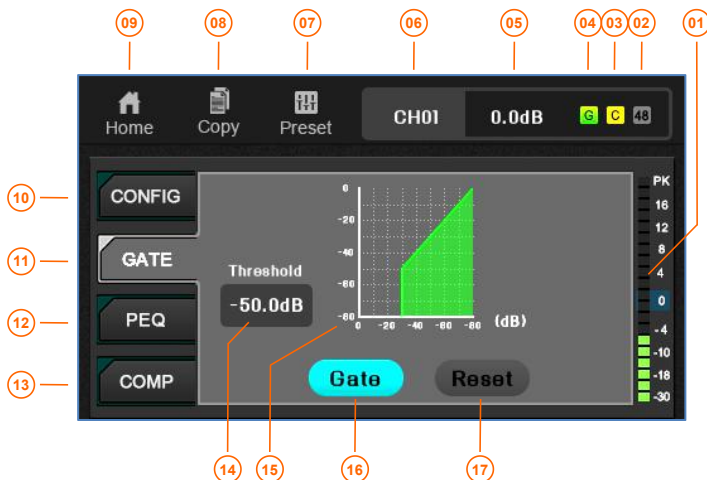

- | | |
|---|---|
| <ul style="list-style-type: none"> 01 Channel level meter, used to measure the strength of the channel signal, in dbu. PK stands for +18dbu and above. 02 48V phantom power symbol, when lit, it indicates that the 48V phantom power output is valid. 03 Compressor symbol, when lit, it indicates that the compressor is active. 04 The noise gate symbol, when it is lit, it indicates that the noise gate is effective. 05 Channel volume gain number, unit db. 06 Channel name. 07 Click to switch to the parameter preset page. 08 Click to switch to the parameter copy page. 09 Home button, click to return to the home page (channel overview menu) 10 Click to switch to the channel CONFIG page. 11 Click to switch to the noise gate page. 12 Click to switch to the PEQ page. 13 Click to switch to the Compressor page. 14 The starting point for setting the threshold to make the signal level attenuate, unit: dB. 15 Gate illustrated, when the active noise gate, the track turns green. 16 Gate switch. Lights up to indicate that the noise gate is active. 17 Reset the parameters to their initial values. | <ul style="list-style-type: none"> 01 Channel level meter, used to measure the strength of the channel signal, in dbu. PK stands for +18dbu and above. 02 48V phantom power symbol, when lit, it indicates that the 48V phantom power output is valid. 03 Compressor symbol, when lit, it indicates that the compressor is active. 04 The noise gate symbol, when it is lit, it indicates that the noise gate is effective. 05 Channel volume gain number, unit db. 06 Channel name. 07 Click to switch to the parameter preset page. 08 Click to switch to the parameter copy page. 09 Home button, click to return to the home page (channel overview menu) 10 Click to switch to the channel CONFIG page. 11 Click to switch to the noise gate page. 12 Click to switch to the PEQ page. 13 Click to switch to the Compressor page. 14 The starting point for setting the threshold to make the signal level attenuate, unit: dB. 15 Gate illustrated, when the active noise gate, the track turns green. 16 Gate switch. Lights up to indicate that the noise gate is active. 17 Reset the parameters to their initial values. |
|---|---|





2.1.4 Parametric equalization (PEQ)

TF-12 equipped every MIC/Line In channel with 4 bands PEQ and High/Low Pass filter.

Note: CH05 ~ CH08 and ST-in channels do not have LPF low-pass filter.



- 01 Channel level meter, used to measure the strength of the channel signal, in dbu. PK stands for +18dbu and above.
- 02 48V phantom power symbol, when lit, it indicates that the 48V phantom power output is valid.
- 03 Compressor symbol, when lit, it indicates that the compressor is active.
- 04 The noise gate symbol, when it is lit, it indicates that the noise gate is effective.
- 05 Channel volume gain number, unit db.
- 06 Channel name.
- 07 Click to switch to the parameter preset page.
- 08 Click to switch to the parameter copy page.
- 09 Home button, click to return to the home page (channel overview menu)
- 10 Click to switch to the channel CONFIG page.
- 11 Click to switch to the noise gate page.
- 12 Click to switch to the PEQ page.
- 13 Click to switch to the Compressor page.
- 14 EQ curve and filter point.
- 15 HPF switch. The filter is effective when it is lit.
- 16 HPF frequency value. Click to select and turn it into blue, and then you can rotate the main jog shuttle to change its value.
- 17 LPF frequency value. Click to select and turn it into blue, and then you can rotate the main jog shuttle to change its value.
- 18 LPF switch. The filter is effective when it is lit.
- 19 PEQ Switch. The equalizer is active when lit.
- 20 Reset all parameters of the EQ to a flat state.
- 21 EQ parameter display area. Click the parameter area or slide up and down in the parameter area to select the parameter to be adjusted, and then use the main jog shuttle to adjust. Press the main jog shuttle to switch between coarse and fine adjustment modes.





2.1.5 Compressor

The Compressor controls the dynamic range of the signal when the signal exceeds the set threshold. The input channels CH01 ~ CH08 have their own independent compressors.

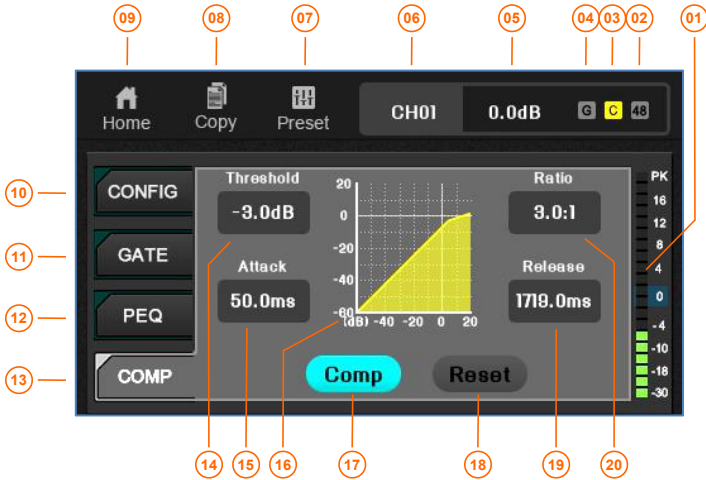

- | | |
|---|--|
| <ul style="list-style-type: none"> 01 Channel level meter, used to measure the strength of the channel signal, in dbu. PK stands for +18dbu and above. 03 Compressor symbol, when lit, it indicates that the compressor is active. 05 Channel volume gain number, unit db. 07 Click to switch to the parameter preset page. 09 Home button, click to return to the home page (channel overview menu) 11 Click to switch to the noise gate page. 13 Click to switch to the Compressor page. 15 Start-up time, adjusts the response speed of the limiter when the signal exceeds the threshold. 17 Compressor switch. Lit means the compressor is on. 19 Release time, adjust the response speed of the Compressor to stop the limit. | <ul style="list-style-type: none"> 02 48V phantom power symbol, when lit, it indicates that the 48V phantom power output is valid. 04 The noise gate symbol, when it is lit, it indicates that the noise gate is effective. 06 Channel name. 08 Click to switch to the parameter copy page. 10 Click to switch to the channel CONFIG page. 12 Click to switch to the PEQ page. 14 Threshold, which sets the starting point for the limiter to start attenuating the signal level. 16 Compressor illustrated. After the compressor is activated, its working track turns yellow. 18 Reset the parameters to their initial values. 20 Sets the ratio of the input level to the output level when the signal exceeds the threshold. |
|---|--|





2.1.6 Copy to

When you have carefully set an input channel, its parameters have met the requirements, and other channels have basic or identical setting requirements with this channel. In this case, the parameter copy function will be used to quickly complete the parameters of other channels settings.

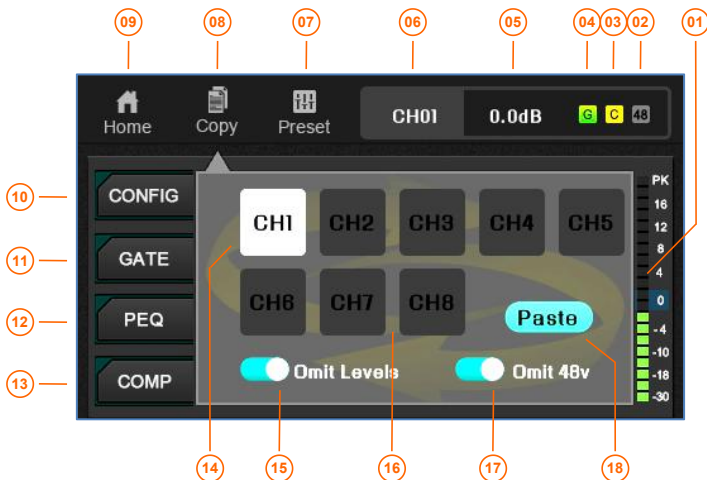

- | | | | |
|----|--|----|--|
| 01 | Channel level meter, used to measure the strength of the channel signal, in dbu. PK stands for +18dbu and above. | 02 | 48V phantom power symbol, when lit, it indicates that the 48V phantom power output is valid. |
| 03 | Compressor symbol, when lit, it indicates that the compressor is active. | 04 | The noise gate symbol, when it is lit, it indicates that the noise gate is effective. |
| 05 | Channel volume gain number, unit db. | 06 | Channel name. |
| 07 | Click to switch to the parameter preset page. | 08 | Click to switch to the parameter copy page. |
| 09 | Home button, click to return to the home page (channel overview menu) | 10 | Click to switch to the channel CONFIG page. |
| 11 | Click to switch to the noise gate page. | 12 | Click to switch to the PEQ page. |
| 13 | Click to switch to the Compressor page. | 14 | The white area is the current channel and the parameters are set. |
| 15 | When turned on, the channel level parameter is ignored when the parameter is copied. | 16 | The blue area is the target channel for which you want to copy parameters. Click to select. Multiple choice. Gray is the unselected channel. |
| 17 | When turned on, the channel name parameter is ignored when the parameter is copied. | 18 | Click this button to copy the parameters of the current channel to the selected target channel. |

Note: In view of the risk of damaging the input device when the 48V phantom power is turned on, the status of the 48V phantom power will not be copied when the channel parameters are copied.





2.1.7 Preset

What is a channel preset? A channel preset is a set of saved parameter settings for a channel that can be recalled at any time. Simply save the adjusted parameters as a preset, and recall them in the future to restore the original working state.

The input presets are suitable for common microphones and instruments. The presets are very useful, the effect is very good, there are few places to be modified, or no modification at all, completely avoiding the cumbersome parameter adjustment work.

Preset the parameters saved by the user to the current settings of the mixer, which can be copied to an external USB flash stick and imported from the USB flash stick.

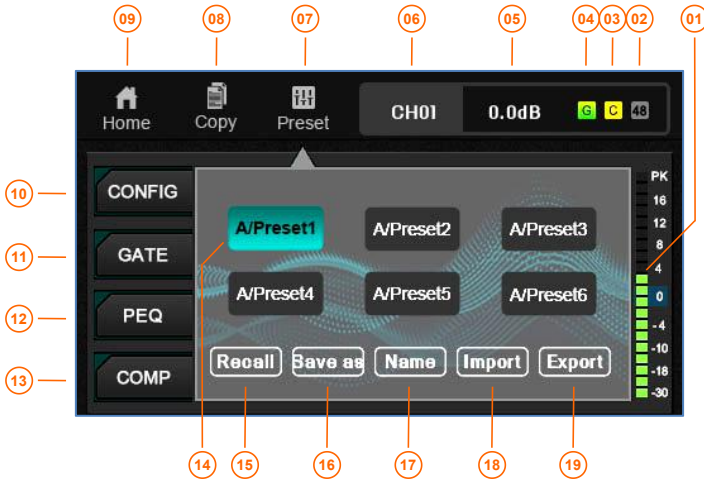

- | | |
|--|--|
| <ul style="list-style-type: none"> 01 Channel level meter, used to measure the strength of the channel signal, in dbu. PK stands for +18dbu and above. 03 Compressor symbol, when lit, it indicates that the compressor is active. 05 Channel volume gain number, unit db. 07 Click to switch to the parameter preset page. 09 Home button, click to return to the home page (channel overview menu) 12 Click to switch to the PEQ page. 14 Click to select a preset as the object of the current operation, so as to call, save, name, import, export, etc. 15 Recall the selected preset parameter. Recall the parameters to the input channel. 17 Rename the selected preset. 19 Copy the selected preset to an external USB stick. | <ul style="list-style-type: none"> 02 48V phantom power symbol, when lit, it indicates that the 48V phantom power output is valid. 04 The noise gate symbol, when it is lit, it indicates that the noise gate is effective. 06 Channel name. 08 Click to switch to the parameter copy page. 10 Click to switch to the channel CONFIG page. 11 Click to switch to the noise gate page. 13 Click to switch to the Compressor page. 16 Save the current channel parameters as user presets and store them inside the mixer. 18 Import the preset parameters from the external USB stick to the selected preset, and store them inside the mixer. |
|--|--|





2.2. Output Channels

2.2.1 Home of output channels



- 01 Compressor symbol, when lit, it means that the compressor is on.
- 02 Channel volume scale, unit db.
- 03 Channel volume fader.
- 04 SOLO button.
- 05 Channel volume value, unit db.
- 06 Channel name. It can be modified in [CONFIG].
- 07 Effect channel control panel.
- 08 AUX output channel control panel.
- 09 Main L/R output channel control panel.

- 10 Fader page .
- 11 Channel volume adjustment.
- 12 Channel mute button.
- 13 Channel selection button, click to enter the channel setting menu, you can set the PEQ, noise gate, compressor, etc.
Click this button again to exit the channel setting mode.
- 14 Channel level meter, unit dbu.
- 15 SOLO control switch button.

(Partial view of TF-12 mixer panel)

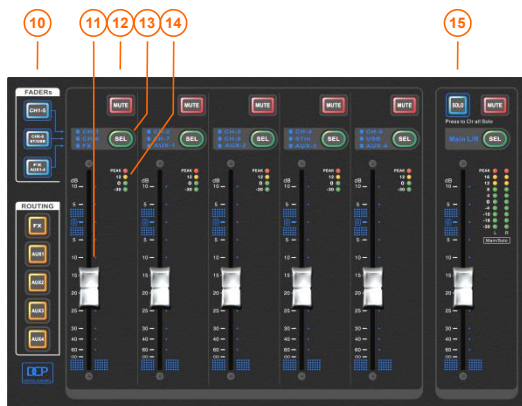



2.2.2 Configuration

The channel settings configure parameters such as channel name and output delay.

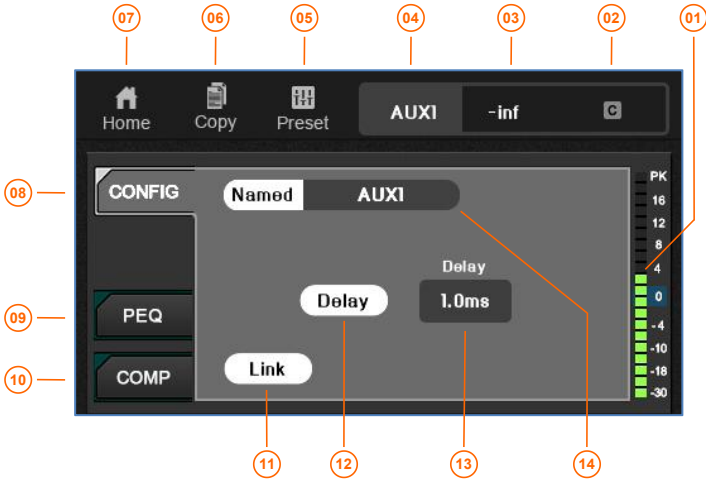

- | | |
|---|--|
| <p>01 Channel level meter, used to measure the strength of the channel signal, in dbu. PK stands for +18dbu and above.</p> <p>03 Channel volume gain number, unit db.</p> <p>05 Click to switch to the parameter preset page.</p> <p>07 Home button, click to return to the home page (channel overview menu)</p> <p>09 Click to switch to the PEQ page.</p> <p>11 Link, the two adjacent MONO channels are linked into a pair of stereo channels. <i>Only channel linking such as (AUX1, AUX2), (AUX3, AUX4), etc. are supported, and channel linkings such as (AUX2, AUX3), (AUX2, AUX3), etc. are not supported. The parameters of the odd channel are automatically copied to the even channel when linked, and the phantom power control is also copied.</i></p> <p>12 Delay switch, the delay is effective when it is on.</p> <p>13 The delay value of the current output channel, click this area, and then rotate the main jog shuttle to change its value.</p> | <p>02 Compressor symbol, when lit, it indicates that the compressor is active.</p> <p>04 Channel name.</p> <p>06 Click to switch to the parameter copy page.</p> <p>08 Click to switch to the channel CONFIG page.</p> <p>10 Click to switch to the Compressor page.</p> <p>14 Channel name. The user can modify it, up to 6 English characters and numbers in length. Click this area to enter the channel naming page.</p> |
|---|--|

2.2.3 PEQ (Same as the input channel, please refer to section 2.1.4)

2.2.4 Compressor (Same as the input channel, please refer to section 2.1.5)

2.2.5 Copy to (Same as the input channel, please refer to section 2.1.6)

2.2.6 Preset (Same as the input channel, please refer to section 2.1.7)





2.2.7 Main L/R channel setup

The Main L/R channel is identical to the other bus output channels. For details, please refer to the previous section. The difference is that the channel name cannot be modified, the route has no volume control, but which input channels can be selected as the source.

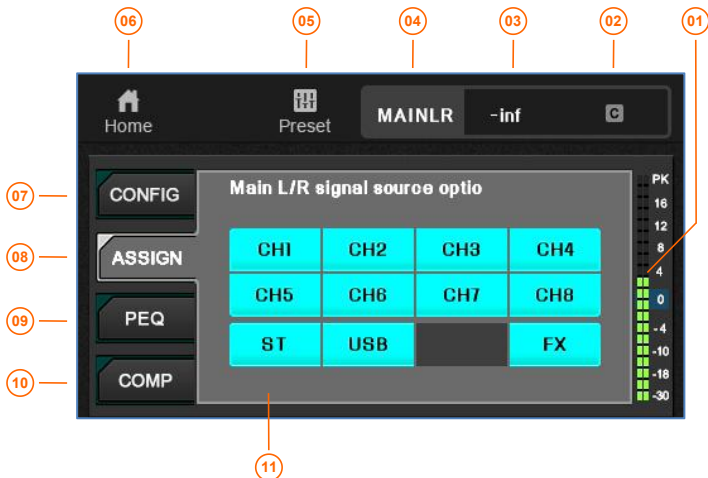

- | | |
|--|---|
| 01 Channel level meter, used to measure the strength of the channel signal, in dbu. PK stands for +18dbu and above. | 02 Compressor symbol, when lit, it indicates that the compressor is active. |
| 03 Channel volume gain number, unit db. | 04 Channel name: Main L/R. |
| 05 Click to switch to the parameter preset page. | 06 Home button, click to return to the home page (channel overview menu) |
| 07 Click to switch to the channel CONFIG page. | 08 Click to switch to the signal assignment setting page. |
| 09 Click to switch to the PEQ page. | 10 Click to switch to the Compressor page. |
| 11 Channel switch, click to switch, the color indicates that the signal of the channel is sent to the Main L/R output. | |





2.3. Route assignment operation

TF-12 has a very powerful and flexible routing function to achieve any input to any output routing control. The input channels CH1~CH8 can achieve completely independent routing settings Pre-Fader or Post-Fader or the AUX1 and AUX2 output buses. Before the routing operation starts, please make the necessary settings for the relevant input channels and output channels according to the previous section. The routing assignment operation is as follows:



[Step 1]: Click the bus area on the left side of the APP screen, and select the output bus that needs routing configuration. Or click the bus button on the mixer panel (as shown in the left picture) to make the TF-12 in the routing setting state. At this time, the input channel that allows routing assignment is displayed in brown. The color of the other channels is not change.

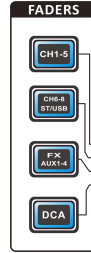

[Step 2]: Use the APP navigation bar to select the group where the input channel is located, or click the fader page button on the mixer panel (as shown on the left), cancel the [mute] of the corresponding input channel, and set the routing volume to a suitable position (as shown in the figure below).

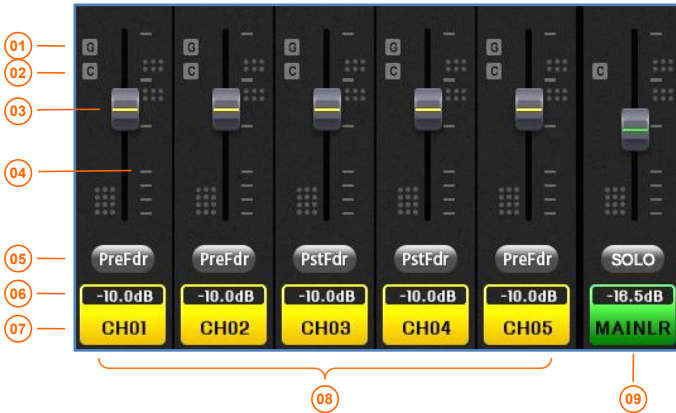

- 01 Noise gate symbol, when it is lit, it means that the noise gate function is on.
- 02 Compressor symbol, when lit, it means that the compressor function is on.
- 03 Route volume fader (fader slider and channel bar is brown). Channels that are not brown cannot be set as routing inputs.
- 04 Channel volume scale, unit db.
- 05 For output buses AUX1 and AUX2, this is a Pre-Fader or Post-Fader selection function, which is not available in AUX3 and AUX4.
- 06 The routing volume of this channel, unit: dB. Change by fader adjustment.
- 07 Channel name.
- 08 Channel control panel.
- 09 Main L/R output channel control panel.





- 10 Fader page.
- 11 Channel volume adjustment.
- 12 Routing channel mute switch. When the red light is on, the channel routing is muted, and no signal is coupled to the bus.
- 13 Channel selection button, click to enter the channel setting menu. Click this button again to exit the channel setting mode.
- 14 Channel level meter, unit dbu.
- 15 SOLO control switch button.

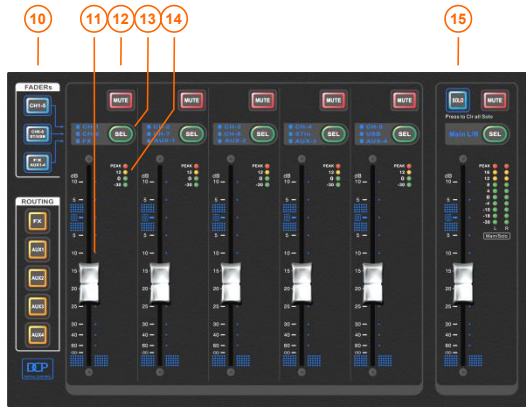

[Step 3]: Repeat step 2 until all routing settings are completed.

[Step 4]: Click the bus button in step 1 again to exit the routing setting mode.

[Step 5]: Adjust the volume of the corresponding AUX output bus on the output fader page.

[Step 6]: So far, the routing setting has been completed.





2.4. Effect processor

The mixer has one effect processing modules FX, it is capable of completing one of 5 effects including Echo, Reverb, Echo + Reverb, Flanger, Stereo Delay.

2.4.1. Signal Chain of FX

The data link graph is shown in the right graph, FX have completely independent effect input buses, can select any input signal source or mixing signal source for effect module. The output of effector is added into the input bus as input, The routing of the AUX output channel can be very flexible to add effects.

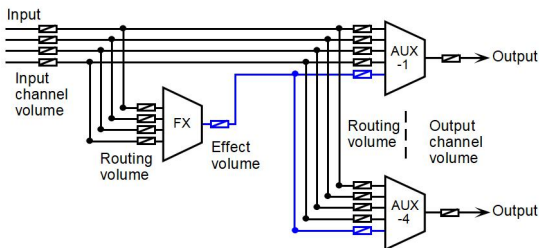

The FX effects engine is completely self-contained and does not occupy any input or output channel resources. Each FX effects engine can independently select different effect types, which is very flexible and completely free of conflicts.

2.4.2. Add effect



[Step 1]: Click the bus area on the left side of the APP screen and select the AUX bus that needs to be added. Or click the AUX bus button on the mixer panel (as shown on the left) to make TF-12 in the routing setting state.

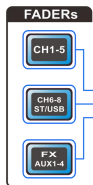

[Step 2]: Use the APP navigation bar to select the group where the FX is located, or click the **FX AUX1-4** button on the mixer panel (as shown in the left picture). Then unmute the routing, adjust the routing volume of the FX, and assign the effect signal to the output bus.

[Step 3]: Follow the steps in Chapter 2.3 [Routing Assignment Operation] to set up routing for FX. Then exit the routing setting state, click the fader page button **FX AUX1-4** to switch to the FX

channel, click the button **SEL** to enter the effect setting menu, and select the effect type, as described in the following chapters.

The right picture shows the effect type selection menu. Click an effect button to select this effect to be effective.

Click [+] to select Echo + Reverb, Click [None] to select no effector, Click [Cancel] without making any changes.

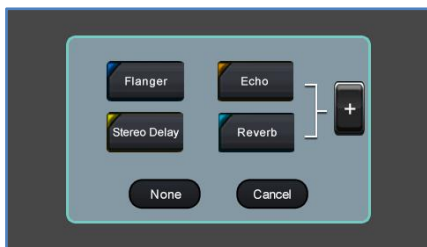



2.4.3. Echo effect

Echo effect is used to create a sense of space and presence.

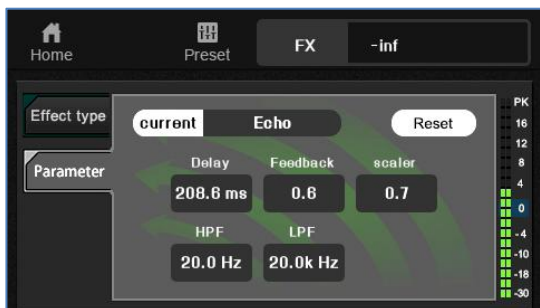

[**Delay**]: Delay, unit: ms. Input signal and feedback signal of delay.

[**Feedback**]: The amount of feedback. The output signal is fed back to the input, and the number of echoes can be changed by changing the amount of feedback.

[**Scaler**]: Echo gain.

2.4.4. Reverb effect

Reverb effect makes the sound become more realistic, full and not dull, and it can also create a different sound amplifying field.



[**PreDelay**]: The time interval between the front-reflection and the direct sound. The bigger the PreDelay, the bigger the space, on the contrary, shorter.

[**DecayTime**]: That's the total length of the whole reverb. The bigger the space, the bigger the decay time.

[**Depth**]: Reverb depth. Feedback strength of post reverb sound.

[**DirectSound**]: Direct sound ratio.

[**ReverbSound**]: Reverb sound ratio.





2.4.5. Flanger effect

Flanger effect can be used to create special effects, such as short-time delay, chorus, tremolo, etc.

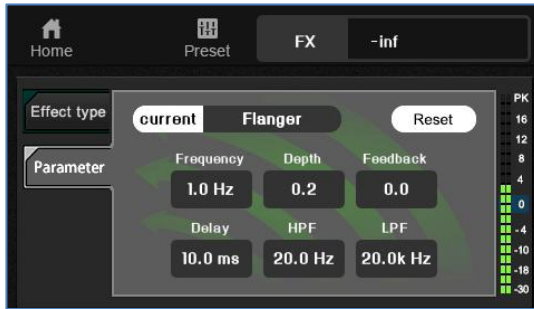

[Frequency]: Modulation frequency. Quick modulation frequency can cause one vibrato effect, but frequency shift will be caused if it is too fast.

[Depth]: Modulation depth. Change the pitch of delay signal through the modulation of delay time, 0 means no modulation, 1 means max modulation.

[Feedback]: The feedback of output delay signal to the input end.

[Delay]: Basic delay, unit: ms.

2.4.6. Stereo Delay

Stereo Delay (ping-pong's sound effect), which has a sound sent out from the left and right channels through the different decay of the left and right channels, like ping-pong's motion trail effect.

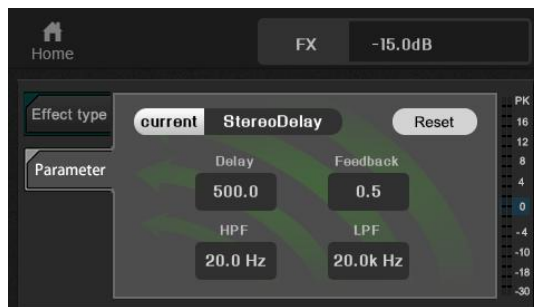

[Delay]: Create an effect of a sound that moves back and forth. The sound is bigger, the effect is more obvious.

[Feedback]: The amount of feedback. Delayed output signal is fed to the input magnitude .





2.4.7. Quick effect selection

According to actual usage, TF-12 is preset with several groups of typical effects by experienced tuner. As shown in the figure below, the user only needs to directly call a certain effect without adjusting the parameters.







2.5. Recording and playback with USB or PC sound card

Click the [CH6-8 / ST / USB] group on the APP navigation bar, and then click the name bar of the USB channel to enter the USB control menu. Or click the button  on the mixer panel to quickly switch to the USB channel menu.

2.5.1 USB playback

USB Media playback, supports MP3, AAC, WAV, AIFF, APE or FLAC file formats.





- | | |
|---|--|
| <p>01 Click this button to switch to the USB stick recording control menu.</p> <p>03 Click this button to switch to the USB stick playback control menu and switch to the U disk working mode.</p> <p>05 Return to the Home page.</p> <p>07 The current progress time of the song, plus timing.</p> <p>09 Song playback progress bar.</p> <p>11 Play or pause. The key  on the panel have the same function.</p> <p>13 The total length of the song.</p> <p>15 List page turning button (Last page).</p> | <p>02 Click this button to switch to the Bluetooth playback control menu.</p> <p>04 Click this button to switch to the PC sound card control menu and switch to the PC sound card working mode.</p> <p>06 Song catalog.</p> <p>08 Play mode, sequence play/single loop, etc.</p> <p>10 The last song. The key  on the panel have the same function.</p> <p>12 The next song. The key  on the panel have the same function.</p> <p>14 List page turning button (Next page).</p> <p>16 Song list scroll bar.</p> |
|---|--|

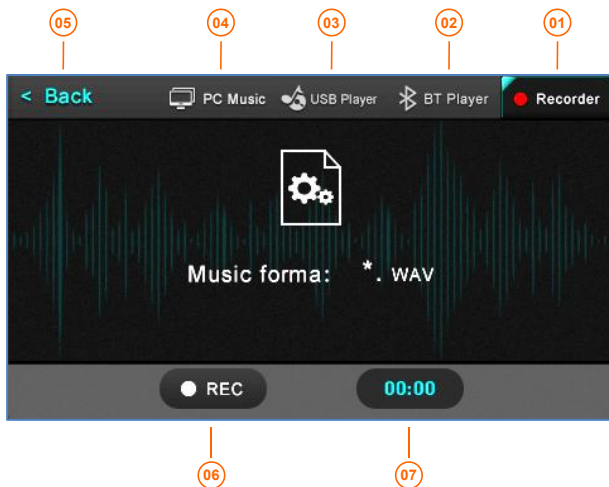

2.5.2 USB recording

You can perform stereo recording by inserting a USB stick into any USB port, and the recording source is Main L/R. USB disk playback and recording can be performed in the same USB stick.



- 01 Click this button to switch to the USB stick recording control menu.
- 02 Click this button to switch to the Bluetooth playback control menu.
- 03 Click this button to switch to the USB stick playback control menu and switch to the U disk working mode.
- 04 Click this button to switch to the PC sound card control menu and switch to the PC sound card working mode.
- 05 Return to the Home page.
- 06 Record button. The keys  on the panel have the same function. Recording is in progress when red.
- 07 Recording progress time.











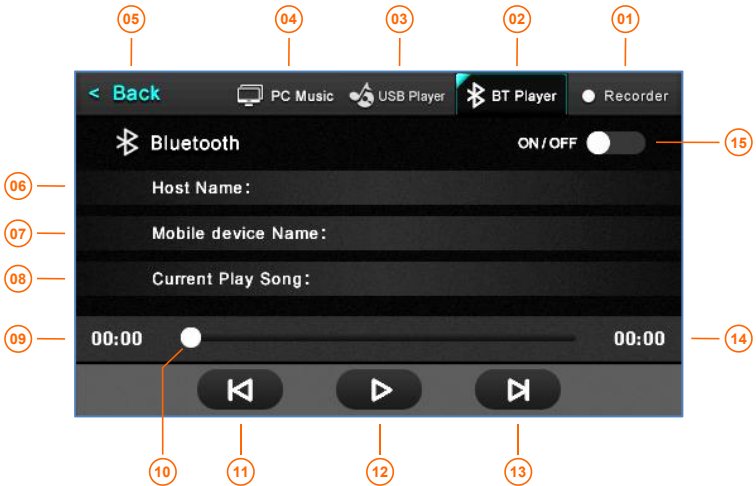

2.5.3 Bluetooth playback

Plug in the USB port Bluetooth adapter that is shipped with the device at any USB port. Switch to the USB control page as shown below. Click the Bluetooth switch to the open position, you can see the host Bluetooth name: TF-12 (user can modify). Then search for available Bluetooth devices in Bluetooth devices such as mobile phones, and click on the device for Bluetooth pairing. After the connection is successful, the system displays the name of the connected device, such as "IPHONE x". The song name and playback progress are displayed after playing Bluetooth music.

TIPS: Since USB disk playback and Bluetooth playback use the same physical resources, in order to avoid conflicts, the system does not allow USB disk and Bluetooth to play at the same time.



- | | |
|--|---|
| <p>01 Click this button to switch to the USB stick recording control menu.</p> <p>02 Click this button to switch to the Bluetooth playback control menu.</p> <p>03 Click this button to switch to the USB stick playback control menu and switch to the U disk working mode.</p> <p>04 Click this button to switch to the PC sound card control menu and switch to the PC sound card working mode.</p> <p>05 Return to the Home page.</p> <p>06 Host Bluetooth name (user click to modify)</p> <p>07 Connected device name (message displayed after successful Bluetooth connection)</p> <p>08 Song name to play (message displayed after successful Bluetooth connection)</p> <p>09 The current progress time of the song, plus timing.</p> <p>10 The last song. The key  on the panel have the same function.</p> <p>11 The last song. The key  on the panel have the same function.</p> <p>12 Play or pause. The key  on the panel have the same function.</p> <p>13 The next song. The key  on the panel have the same function.</p> <p>14 The total length of the song.</p> <p>15 Bluetooth switch.</p> | <p>01 Click this button to switch to the USB stick recording control menu.</p> <p>02 Click this button to switch to the Bluetooth playback control menu.</p> <p>03 Click this button to switch to the USB stick playback control menu and switch to the U disk working mode.</p> <p>04 Click this button to switch to the PC sound card control menu and switch to the PC sound card working mode.</p> <p>05 Return to the Home page.</p> <p>06 Host Bluetooth name (user click to modify)</p> <p>07 Connected device name (message displayed after successful Bluetooth connection)</p> <p>08 Song name to play (message displayed after successful Bluetooth connection)</p> <p>09 The current progress time of the song, plus timing.</p> <p>10 Bluetooth playback progress is displayed. Can't fast forward/rewind operation.</p> <p>11 The last song. The key  on the panel have the same function.</p> <p>12 Play or pause. The key  on the panel have the same function.</p> <p>13 The next song. The key  on the panel have the same function.</p> <p>14 The total length of the song.</p> <p>15 Bluetooth switch.</p> |
|--|---|





2.5.4 PC sound card recording and playback

TF-12 provides a high-quality PC virtual sound card function. The PC sound card can be used to easily connect to the computer to realize the playback and recording of the PC to the mixer, which can be realized by live broadcast.

The first time you connect the mixer to the PC computer, the driver will be automatically installed, and the sound card device will be automatically generated in the computer, usually the device name is: Raymax Audio. At the same time, switch to PC sound card mode in the TF-12 mixer (click the [PC sound card] button on the screen).

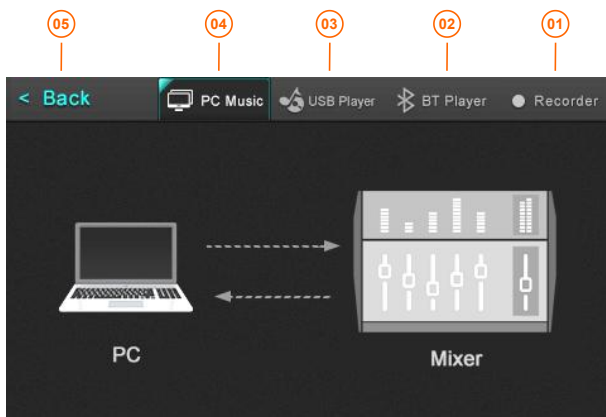

- 01 Click this button to switch to the USB stick recording control menu.
- 02 Click this button to switch to the Bluetooth playback control menu.
- 03 Click this button to switch to the USB stick playback control menu and switch to the U disk working mode.
- 04 Click this button to switch to the PC sound card control menu and switch to the PC sound card working mode.
- 05 Return to the Home page.

NOTE: If the mixer is in PC sound card mode, USB disk playback, Bluetooth playback and USB disk recording functions will be prohibited and cannot be used! !





2.6. Overview of the function map

The exclusive Overview global function link overview menu, the complete processing of the audio signal from input to output is clear at a glance, and the parameter setting can be performed by clicking

the corresponding node. The system provides a shortcut button , click to enter this Overview menu.

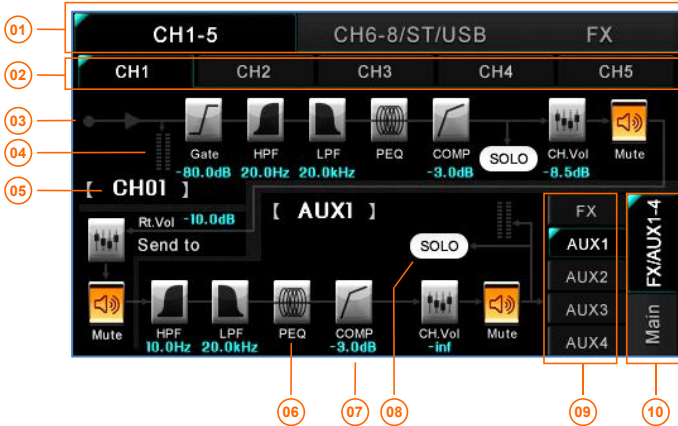

- 01 Input channel group label, select the corresponding group according to the input channel.
- 02 Input channel list, click to select the required input channel.
- 03 A complete signal link diagram from the selected input channel to the selected output channel, including level indication, function processing, volume setting, routing, solo, etc.
- 04 Level meter indication.
- 05 Channel name.

- 06 Function diagrams and function names. Colored icons are used for valid functions, and gray icons are used for closed functions.



Click to enter the function setting menu to modify the parameters, and click  again to return to this Overview menu.

- 07 The key parameters of the function node.
- 08 SOLO switch.
- 09 Output channel list, click to select the required output channel.
- 10 Output channel group label, select the corresponding group according to the output channel.





2.7. System settings

The system setting menu is used to set or browse system parameters and configurations. Click the button  on the mixer panel or  on the APP homepage interface to enter the system setting menu, as shown in the figure below.

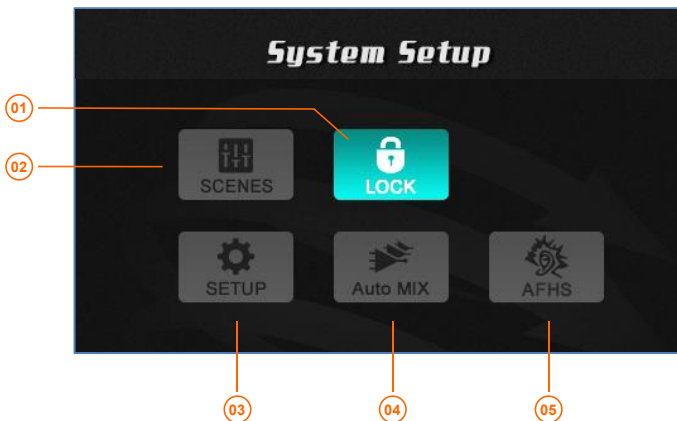

- 01 In order to avoid confusion caused by accidental touch or operation of the mixer, the system is equipped with a lock function. After the lock function is turned on, the mixer is no longer controlled by the outside (except for analog volume gain). Click this button again to unlock.
- 02 Click to enter the scene control menu. (See Chapter 2.7.1 for details)
- 03 Click to enter the system parameter setting menu. (See Chapter 2.7.4 for details)
- 04 Click to enter the automix setting menu. (For details, see section 2.7.2)
- 05 Click to enter the howling suppression setting menu. (For details, see section 2.7.3)





2.7.1 SCENES

What is a scene? A scene is a set of pre-saved settings that can be retrieved at any time and set all parameters of the TF-12 digital mixer to the value of the scene.

A scene includes all channel processing settings, channel names, phantom power settings, effect selection, and level settings.

The TF-12 mixer contains 6 groups of preset scenes for various performance occasions. For the performance you are about to tune, you can find the most suitable scene. Use scene presets to quickly configure the mixer to the working state you need.

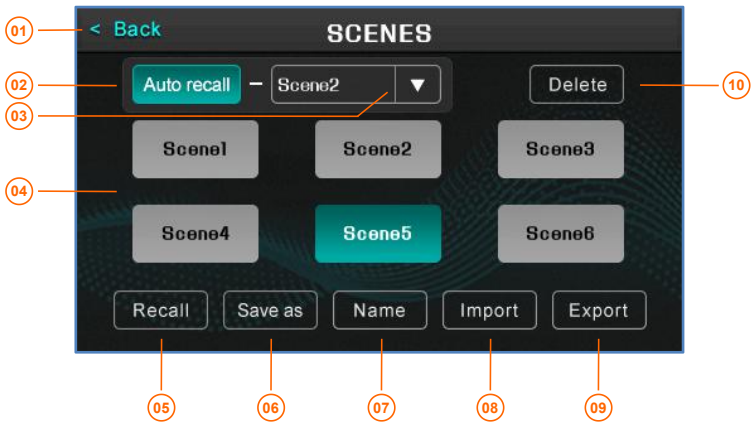

- | | |
|--|--|
| <p>01 Home button, click to return to the home page (channel overview page)</p> <p>03 Click and select the scene from the drop-down menu that needs to be loaded automatically when the mixer starts.</p> <p>05 Recall the selected scene mode and restore the mixer to the original setting state according to the parameters of the scene.</p> <p>07 Rename the selected scene.</p> <p>09 Copy the selected scene to an external USB disk.</p> | <p>02 Choose whether to automatically load preselected scenes when the mixer starts up. The button lights up to indicate that the scene is automatically loaded.</p> <p>04 Click to select a scene as the object of the current operation for calling, saving, naming, importing, exporting, delete etc.</p> <p>06 Save the current mixer parameters as a user scene and store it inside the machine.</p> <p>08 Import the scene parameters from the external USB disk to the selected scene and store them inside the mixer.</p> <p>10 Delete the selected scene.</p> |
|--|--|





2.7.2 Automatic microphone mixing control (AMMC)

What is automatic mixing? When a person speaks, the system quickly assigns gain to the MIC, while other silent MICs are automatically pulled down. When the speaker stops talking, the volume of this MIC is pulled down. The next person speaks, the system quickly assigns gain to the MIC, while the other silent MICs are pulled down. The result sounds like a MIC is quickly passed between several speakers.

When multiple people speak at the same time, the gain of the MIC will be shared and all MIC sounds will be used normally, but the background noise will not increase due to the increased number of MICs, or acoustic feedback will occur. The system provides the [Minimum Gain] option to ensure that the MICs in the call have the proper volume gain for normal calls, but the MICs with high privileges will have a relatively high volume.

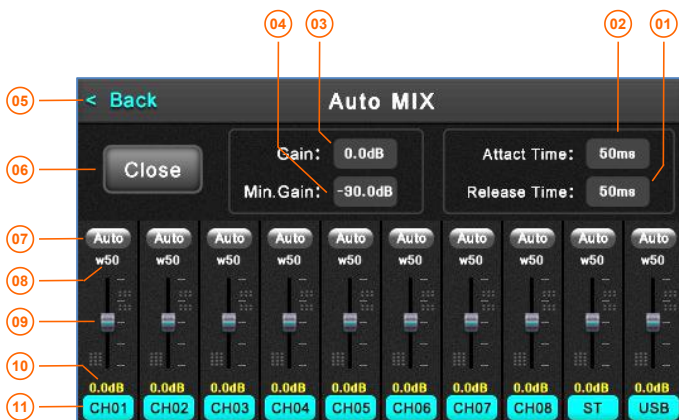

- 01 Release time: When the MIC of a channel does not speak for more than this time, the system will determine that the microphone of this channel stops talking and its corresponding route volume will be pulled down to -60dB.
- 02 Start time: When the MIC of a channel continues to speak for more than this time, the system will determine that the microphone of this channel starts to talk, and its corresponding routing volume will be based on the gain sharing principle, and the microphone volume gain will be allocated according to the weight ratio of all the calls.
- 03 Set the gain of the Automix. Avoid multi-MIC gain too low when talking at the same time, and also coordinate the volume ratio of the automatic mixing channel and the channel that does not participate in the automatic mixing.
- 04 Set the minimum gain to participate in the automix channel to ensure that the lower priority channel also has the right amount of volume.
- 05 Home button, click to return to the home page (channel overview page)
- 06 Automatic mixing switch, the automatic mixing function takes effect when it is lit.
- 07 Input channel auto mix switch, [Auto] indicates that the current input channel participates in automix.
- 08 Channel weight value. The greater weight, the higher gain assigned and the greater volume of the channel.
- 09 The weight of the channel is assigned. The weight range is 0~100, and 100 is the maximum weight. The system counts the weights of all channels participating in the auto mix and assigns the actual channel gain based on the weight.
- 10 The current actual gain of the channel, the channel participating in the automatic mixing, whose gain will be automatically assigned by the system through intelligent algorithms.
- 11 Input channel label.





2.7.3 Acoustic feedback howling suppression (AFHS)

When using a microphone as an input source, howling caused by acoustic feedback is usually a headache. The TF-12 digital mixer is equipped with a dedicated howling suppression bus, which provides two independent modules, dynamic howling suppression and trapped howling suppression, which can be selected separately or simultaneously according to the actual situation.

Whether to add the howling suppression function to the input channel, please select in the [CONFIG] menu of the input channel. Howling suppression is only valid for Main L/R output channels, AUX output channels and FX effect channel have no howling suppression function.

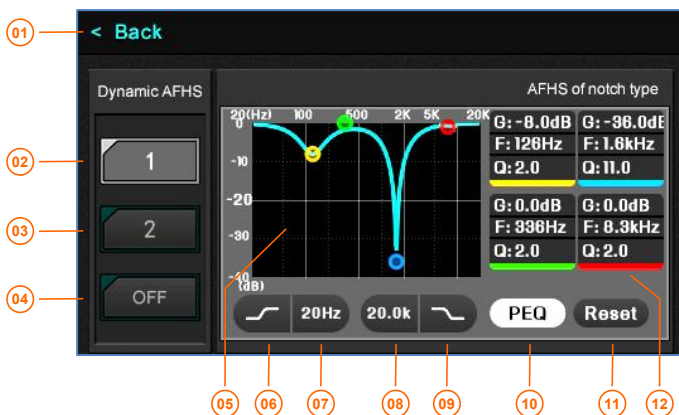

- | | |
|---|--|
| <ul style="list-style-type: none"> 01 Home button, click to return to the home page (channel overview page) 02 Dynamic howling suppression: the first level 03 Dynamic howling suppression: the second level (strong suppression ability) 04 Dynamic howling suppression: off 05 EQ notch filter curve and filtering point. 06 HPF switch. The filter is effective when it is lit. 07 HPF frequency value. Click to select and turn it into blue, and then you can rotate the main jog shuttle to change its value. 08 LPF switch. The filter is effective when it is lit. 09 LPF frequency value. Click to select and turn it into blue, and then you can rotate the main jog shuttle to change its value. 10 Notch filter switch. The notch filter is effective when it is on. 11 Reset all the parameters of the EQ trap to the flat state. 12 EQ notch filter parameter display area. Click the parameter area or slide up and down in the parameter area to select the parameter to be adjusted, and then use the main jog shuttle to adjust. Press the main jog shuttle to switch between coarse and fine adjustment modes. | <ul style="list-style-type: none"> 02 Dynamic howling suppression: the first level 04 Dynamic howling suppression: off 06 HPF switch. The filter is effective when it is lit. 08 LPF frequency value. Click to select and turn it into blue, and then you can rotate the main jog shuttle to change its value. 10 Notch filter switch. The notch filter is effective when it is on. |
|---|--|





2.7.4 Settings and system information

The system parameter and information menu is used to set general system functions.

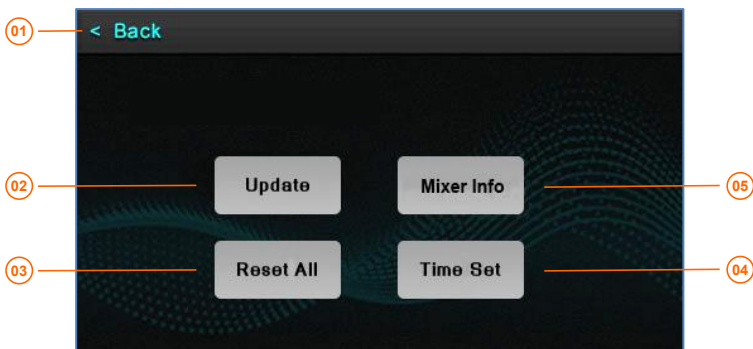

- 01 Home button, click to return to the home page (channel overview page)
- 02 Click to enter the system upgrade menu. (For details, see section 2.7.4.1)
- 03 The mixer is restored to the factory state. User settings will be cleared.
- 04 Click to enter the settings menu. The current system date and system time. Click the content to be modified on the screen, then turn the main jog shuttle on the panel to change its value, and the result will be saved automatically.
- 05 Related information about this mixer, such as hardware and software version, date of manufacture, etc. (For details, see section 2.7.4.2)

2.7.4.1 Firmware Upgrade

The TF-12 Digital Mixer supports the powerful **ISUeasy™** full firmware upgrade feature, and any software feature can be easily upgraded with **ISUeasy™** as long as it does not involve hardware circuit changes. Make sure that the equipment you purchase is always in the best working condition and enjoy the latest added features in the first place. Continuous quality service is our constant commitment !!

- 1). Log on to our website and download the appropriate update software to your U stick root directory .

Note : *The upgrade file must be placed in the root directory of the U disk, and the file name and extension name can not be changed !!*

- 2). Turn on the power of TF-12 mixer, wait till the system starts up and enters normal operating conditions.
- 3). Enter the system settings menu, Click [Upgrade] on the screen. Start the firmware upgrade program **ISUeasy™**. Read the precautions carefully and confirm that it is correct. Click [Continue] to perform the upgrade process.

The upgrade process takes a few minutes, please be patient. Do not power off during this process to avoid the upgrade failure and equipment failure !!





2.7.4.2 Device Information & Network settings

The device information page provides important information about software and hardware versions
(Note: Products supplied starting from July 2024 will no longer provide WIFI hotspot functionality and will not be equipped with WIFI adapters.)



- 01 Home button, click to return to the home page (channel overview page)
- 02 Version information of this device, hotspot IP number and network IP number.
- 03 After modifying the name SSID and password, click this button to restart WIFI for it to take effect.
- 04 The name of the WIFI can be modified by the user.
- 05 WIFI connection password, user modify settings.

2.8. APP connection and usage guidelines

The digital mixer has LAN/IP networking function and can be easily remotely controlled using an Android or IOS tablet.

- 1) Connect the mixer to the local area network via ethernet cable and set the IP address of the mixer.
- 2) Log in to the Apple App Store with your iPad, search for apps using the keyword "TF-12", and install them on your iPad.
- 3) If it is an Android tablet or phone, an Android version of the app needs to be installed.
- 4) To run the app for the first time, you need to set the correct IP address: click on the "≡" icon button in the upper left corner of the app, set the same IP address as the mixer in "Change Connection", confirm and return to automatically connect.

Not the first time running the APP program. When the network connection icon on the app turns green, it indicates that the app has established a communication connection with the digital mixer and can now be remotely controlled.



2.9. Programmable central control remote operation

Using the device's network port, this digital mixer can accept remote control commands from the center console. Through the centralized control of the programmable central control unit, you can quickly and efficiently control the main parameters of the digital mixer, such as input/output volume and mute control, as well as scene calls, and so on.

The easy-to-understand ASCII command language, flexible and extensible syntax structure, direct parameter assignment or incremental/decrement assignment, can also read back the current parameter values of the mixer. For detailed communication protocols and requirements, see "AIMIX Digital Mixer Central Control Communication Protocol".





2.10. Control through interface RS-485

2.10.1 Connecting the central control equipment

When connecting external central control equipment through RS-485 interface, see “AIMIX Digital Mixer Central Control Communication Protocol” for detailed communication protocol and requirements.

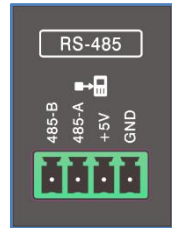

2.10.2 Connect 86 boxes of wallboard controllers

The external 86 box wallboard controller can communicate and control with the mixer through RS-485 interface. The mixer works in the master mode, and all 86 boxes of controllers work in the slave mode, thus allowing more 86 boxes of controllers (up to 64) to use a simple bus to connect with the mixer and achieve synchronous control.

The mixer provides 5V power output, limiting the maximum current of 500mA. Generally, it can provide reliable operation for two 86 box controllers. If the number of 86 box controllers exceeds two, other measures should be taken to provide additional power.

(86 boxes of wallboard controllers are optional accessories)

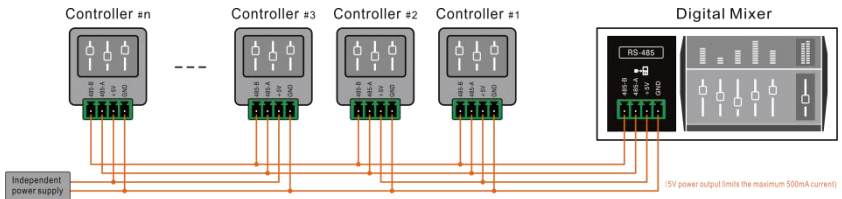

Wiring diagram of 86 box wallboard controller

86 boxes of wallboard controller software menu (partial only):





TF-12

Mixer Reference





Appendix 1. Technical performance parameters

(The key performance parameters are derived from the standard test method. Test equipment: Professional audio analyzer APx525 / SN: APX2-28556 of Audio Precision Co.,Ltd.,US. All are direct results of unweighted testing.)

A). General specifications

Display screen	4.3" high-definition color TFT LCD screen and capacitive touch screen.
Faders	100mm electric intelligent control, accuracy = 1024 position, + 10dB / - 60dB / - ∞ , full electric Fader
Audio Input	12 channels input: 8 channels Mic/Line(XLR/TRS balanced interface), 1 stereo line input, 1 stereo USB Media channel (U disk playback or Bluetooth audio) or PC sound card playback.
Audio output	10 channels output: 4 way auxiliary output AUX1 ~ AUX4 (XLR balanced port) 2 way main output (XLR balanced port) 1 stereo channel USB recording or PC sound card recording 1 stereo monitor (1/4" TRS stereo port and 16Ω minimum impedance headphone)
Input channel processing	Analog gain adjustment (Gain), Polarity selection, 4-bands parametric equalization (PEQ), high-pass filter low-pass filter, noise gate and compressor.
Output channel processing	High-pass and low-pass filters, 4-bands parametric equalization (PEQ),compressor and delay (max 500ms).
Recording function	Stereo two-channel recording, with Main-L/R as the recording source. U disk recording or PC sound card recording.
U disk playback	Supports MP3, AAC, WAV, AIFF, APE or FLAC file formats.
PC sound card	Play and record simultaneously. 48kHz / 24bit, no need to install driver.
Effectors	1 professional effectors: Echo, Reverb, Echo+Reverb, Flanger and Stereo Delay, 5 kinds of effect processing, 60 factory presets(FX Presets), simple and easy presets for users.
Presets	Presets of mixer: User presets include saving or recalling all mixer parameters from the internal and U disk to mixer. Channel presets: User channel presets can be saved or recalled from the internal and U disk to mixer.
Scene mode	[Save] / [Recall] / [Name] / [Export] / [Import] of scenes can be realized.
Howling suppression	Dynamic howling and notch howling suppression dual modules.
Automatic mixing	Intelligent gain sharing adaptive algorithm.
Pre-Fader or Post-Fader	The routing of AUX1 and AUX2 buses supports setting Pre-Fader or Post-Fader.
External control	Android or Apple iPad digital audio interactive management APP software, access and control almost all parameters of the device through IP, remote control operation is easy and comfortable. It can also be controlled remotely through the central control protocol. RS-485 interface, supports external 86 box wall panel controllers. (Main mode, can connect multiple slave mode wall panel controllers)
Bluetooth	USB Bluetooth adapter package is included.
Wireless microphone (optional purchase)	UHF, 2 MICs, dual channels Effective receiving distance of 60 meters (short antenna) / 100 meters (long antenna). Infrared pairing.
Sampling frequency / quantization bits	48kHz / 24bit
Signal delay	Less than 3 milliseconds, from any input to output
Profile dimension and weight	Product (without packaging): 355mm(W) x 403mm(D) x 98mm(H) / 4.7 kg Product (including packaging): 530mm(W) x 390mm(D) x 130mm(H) / 5.9 kg
Working voltage	100Vac~240Vac, 50~60 Hz, 30W _{MAX}
Temperature range	Operating temperature range: 0°C to 40°C , storage temperature range: - 20°C to 60°C





B). Analog characteristics

(The "Actual measured value" in the table is for reference only, there may be a 5% deviation due to environmental and machine differences)

Channel tested	Parameter name	Actual measured value	Test conditions and instructions
MIC/Line Input channel	Analog gain	-5 ~ +55dB	±10%
	Maximum input level	+25.3dBu (14.26V _{rms})	Min Gain -5dB
	Channel noise	-84.5dBu (46.1uV _{rms})	Min Gain -5dB, A-wt, Do not suspend the input port
		-74.1dBu (152.8uV _{rms})	Max Gain +55dB, A-wt, Do not suspend the input port
	THD+N	0.008% (-81dB)	Min Gain -5dB, +4dBu /1kHz
	Dynamic Range	104.7dB	Min Gain -5dB, +24dBu@1kHz, A-wt
	S/N ratio	104.2dB	Min Gain -5dB, +24dBu@1kHz, A-wt
	Equivalent Input Noise	-129.1dBu (0.272uV _{rms})	Max Gain +55dB, A-wt Do not suspend the input port
	Frequency response	±0.08dB	Min Gain -5dB, +4dBu /20Hz-20kHz
Channel crosstalk	-103.5dB	Gain(9 o'clock position), +4dBu@10kHz	

Channel tested	Parameter name	Actual measured value	Test conditions and instructions
ST-in Input channel	Analog gain	-5 ~ +32dB	±10%
	Maximum input level	+25.5dBu (14.59V _{rms})	Min Gain -5dB
	Channel noise output	-85.2dBu (42.6uV _{rms})	Min Gain -5dB, A-wt, Do not suspend the input port
		-84.2dBu (47.8uV _{rms})	Max Gain +32dB, A-wt, Do not suspend the input port
	THD+N	0.008% (-81dB)	Min Gain -5dB, +4dBu /1kHz
	Dynamic Range	105.1dB	Min Gain -5dB, +24dBu /1kHz, A-wt
	S/N ratio	104.6dB	Min Gain -5dB, +24dBu /1kHz, A-wt
	Equivalent Input Noise	-116.2dBu(1.20uV _{rms})	Max Gain +32dB, A-wt Do not suspend the input port
	Frequency response	±0.08dB	Min Gain -5dB, +4dBu /20Hz-20kHz
Channel crosstalk(L&R)	-80.1dB	Gain(9 o'clock position), +4dBu@10kHz	

Channel tested	Parameter name	Actual measured value	Test conditions and instructions
Main /AUX1-4 Output channel	Redundant output noise	-94.5dBu(14.59uV _{rms})	A-wt
	Maximum output level	+20.1dBu(7.836V _{rms})	Differential balanced output

C). Wireless microphone module specifications (optional purchase)

(The "Actual measured value" in the table is for reference only, there may be a 5% deviation due to environmental and machine differences)

Parameter name	Actual measured value	Parameter name	Actual measured value
Effective use distance	About 100 meters (The actual distance is related to the use environment)	Pickup sensitivity	< -55dB ± 3dB (0dB = 1V / Par at 1kHz)
Total selectable frequency points	200 in total, 100 on each side	Pickup	Moving coil type, super heart type
Frequency Range	650 ~ 700 MHz	Transmitter output power	30mW
RF generation method	Phase-locked loop frequency synthesizer	Dynamic Range	>95dB
RF frequency	+/- 5ppm <10kHz	System S/N	>98dB (A-wt, @max output)





TF-12

Mixer Reference



.....

accuracy			
----------	--	--	--





Appendix 2. The Mixer Block Diagram

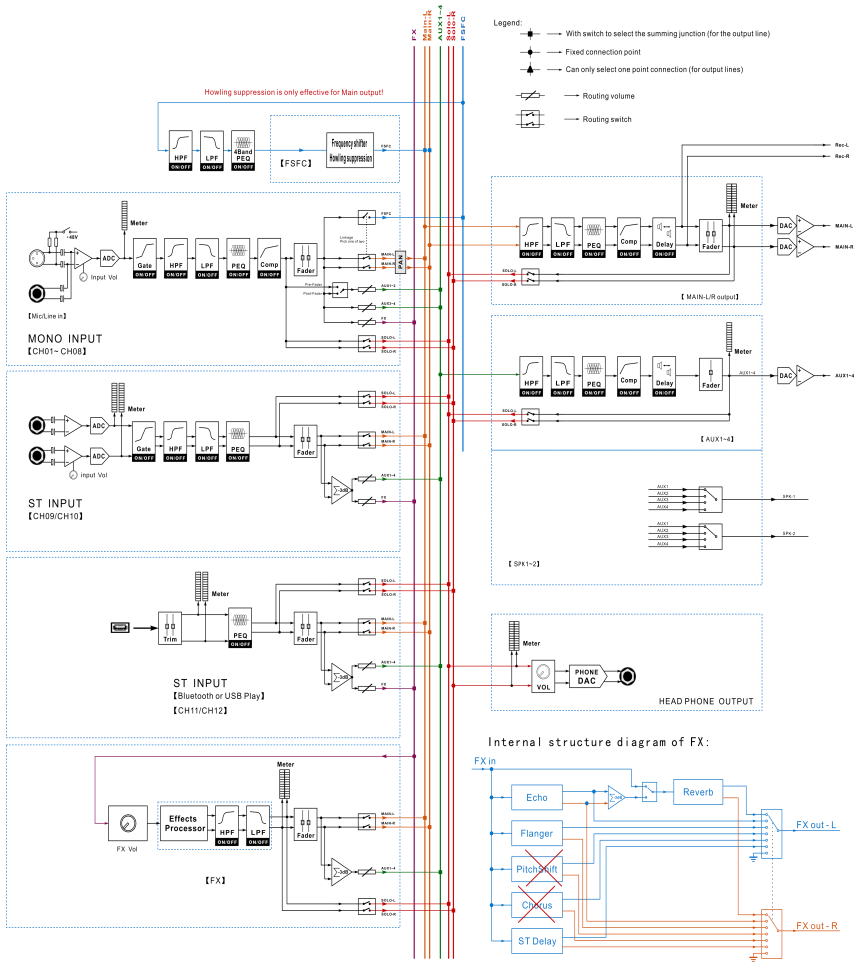



Appendix 3. Dimensions

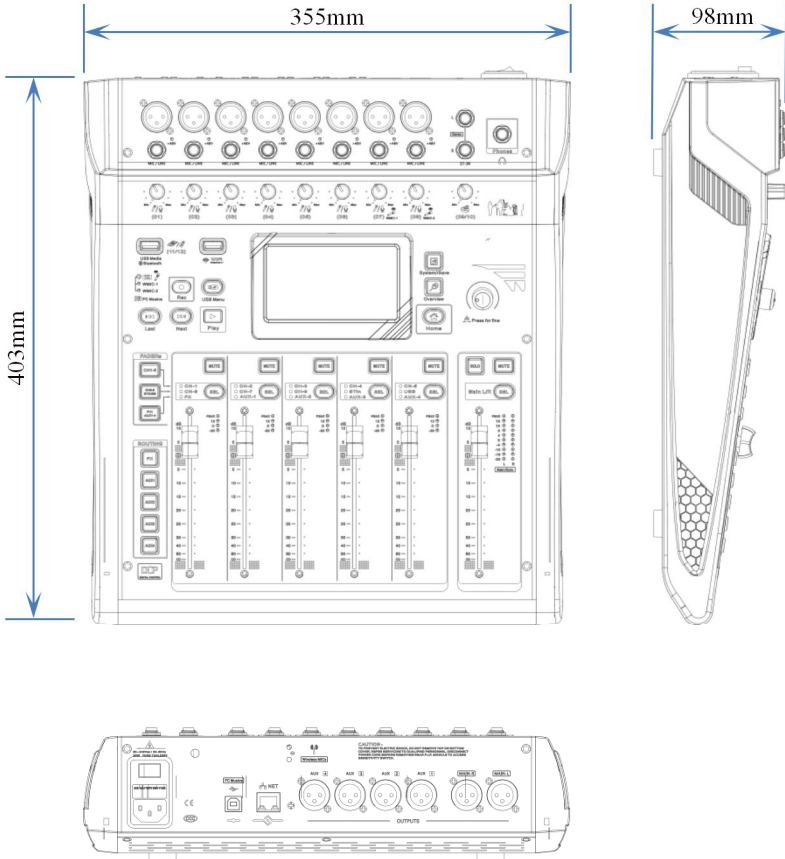



Appendix 4. Operating guidelines for wireless MIC (optional)

[Wireless MIC volume adjustment] :

- Under normal working conditions, long press the [+] or [-] buttons for 1 second to enter the volume adjustment state, continue to press or short press to adjust the volume. The level is 1~9 (1 = 30% Max vol, 2 = 40%, 3 = 50%, 4 = 60%, 5 = 70%, 6 = 79%, 7 = 87%, 8 = 94%, 9 = 100%, the initial state is 6);
- The display XXX.XXX shows: VoL 01-09, do not operate the button for 3 seconds to exit the volume adjustment and return to the normal display.

[Frequency Selection and Infrared Linking] :

- Long press the [Setup] button for 3 seconds to enter the frequency adjustment state, and then press the [Setup] button for 3 seconds to change the frequency band (L section = 650 ~ 674.75MHz and H section = 675 ~ 699.75MHz).
- After entering the frequency adjustment state, the display screen XXX.XXX flashes slowly, the frequency is Hz;
- In the state of adjusting the frequency, short press or long press the [+] or [-] buttons to adjust the frequency one by one or continuously. The frequency is only adjusted in the selected frequency band and can be cycled;
- In the state of adjusting the frequency, short press the [Setup] key to transmit the linking signal, and the linking lamp will light up for about 5 seconds. Point the infrared port of the wireless MIC at the [IR] receiver on the mixer, and you can complete the frequency linking operation at this time. If it is not aligned, the receiver signal indicator will not light up, you can short press the [Setup] key again.
- Do not operate the button, 5 seconds after the linking light goes out, the linking state will be exited.

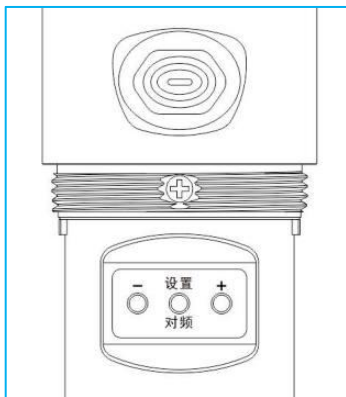
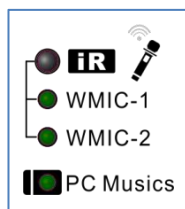

[Receiver signal indicator] :

- No MIC connected: off
- Connect the MIC: light up
- MIC mute : flashes slowly

Note : The MIC display: XXX.XXXL / XXX.XXH. Frequency adjustment is 0.25MHz single or continuous addition and subtraction.

MIX | **TF-12**
Showing rich sound connotations



Dongguan 3G Audio Technology Co., Ltd.



UG·TF12·EN/V2.0·210508

Add: Building 3, No.1 Nanqi street, Qiaodong road,
Qiaotou town, Dongguan City,
Guangdong province, 523800 China

Website: www.beta3pro.com