



Beta Three

Ra15





Beta Three

CONTENTS

	-----	1
SPECIFICATION	-----	1
SPEAKER CONTROL PANEL	-----	2
APPLICATION EXAMPLE	-----	3
ACOUSTIC CHARTS	-----	5
INSTALLATION	-----	9
DIMENSIONS	-----	9
SAFETY INSTRUCTIONS	-----	10
LIMITED WARRANTY	-----	11

PRODUCT FEATURES

Two transducers two way full range plastic speaker with coaxial design, Computer simulation design.

One 15 inch woofer and 34 mm compression driver.

HF/LF transducers are coaxially mounted sharing the same acoustic axis.

horn can be turned 90°.

Wide dispersion: 90°x 40°

It is applied for full range sound reinforcement.

Suitable for monitor, meeting, large performance and so on.

Various installation possibilities allow flying, standing or wall mounting.

SPECIFICATION

Transducers:	LF: 1"x1; HF:1."x1
Frequency Response(-3dB)	50Hz -20kHz
Input Sensitivity	In 500mv/20mv
Rated Impedance	8Ω
Max SPL(1m)	120/126dB
Amplifier Power Output	400W
Range for volume	s11.5dB
Dispersion(HxV)	90°x40° / 40°x90°
Crossover Point	3kHz
THD	<3%
Input Connectors	Input: 6.35; Output: 6.35
Power Supply	AC 220V -240V~, 50/ 60Hz
Net Weight	20.5kg
Gross Weight	23.5kg
Dimensions (WxHxD)	488x412x606mm
Packing Dimensions(WxHxD)	538x468x672mm

FUNCTION INTRODUCTION FOR SPEAKER S BACK PANEL

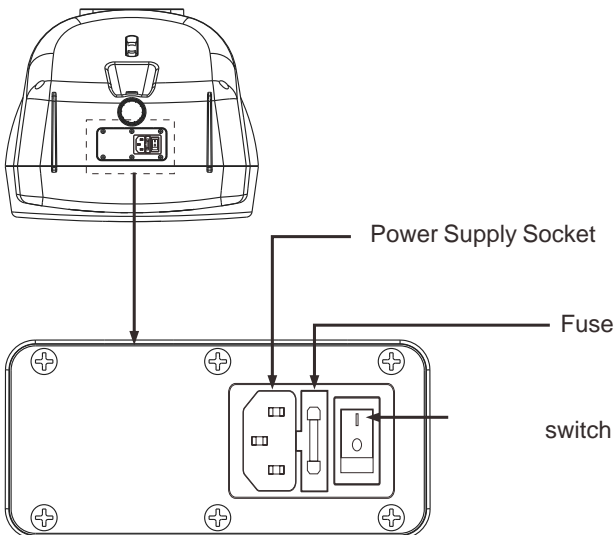
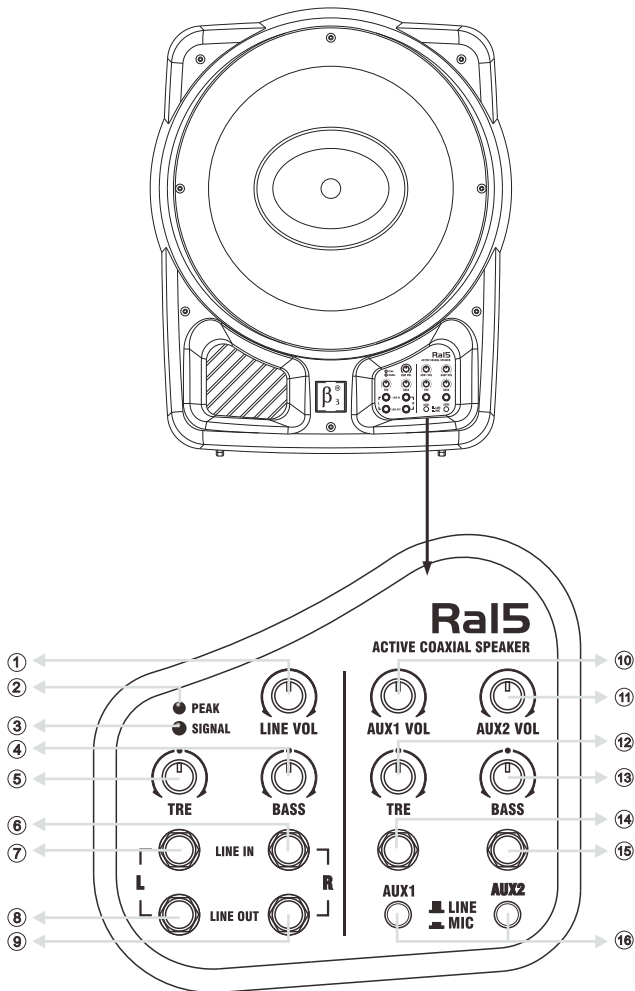

1. volume control for (7)L and (6)R, increase by turning clockwise, decrease by turning counter-clockwise.
Attention: Please adjust the volume to Min, when inputting signal and outputting, then adjust according to the application demand.
2. Overload indicator.
3. signal indicator.
4. Bass control for (7)L -LINE IN, increase by turning clockwise, decrease by turning counter-clockwise.
5. Treble control for (7)L -LINE IN, increase by turning clockwise, decrease by turning counter-clockwise.
6. Line in socket, The signal on Line in is controlled by (1) volume, which will be transferred to (9)LINE OUT for outputting.
7. Line in socket. It is available for only one signal source.
8. Signal output socket. Output signal.
9. Signal output socket. Transfer the signal on (7)LINE IN to the signal input socket of another active speaker. It is also the signal output of AUX1/AUX2 which controlled by (10)(11).
10. AUX1 volume control, increase by turning clockwise, decrease by turning counter-clockwise, Be off at the Min. position.
11. AUX2 volume control, increase by turning clockwise, decrease by turning counter-clockwise, Be off at the Min. position.
12. Treble control for AUX1 and AUX2, increase by turning clockwise, decrease by turning counter-clockwise.
13. Bass control for AUX1 and AUX2, increase by turning clockwise, decrease by turning counter-clockwise.
14. Signal input of AUX1.
15. Signal input of AUX2.
16. Option Switch of Mic and Line. Mic is available when pressing switch down. Line will be available when releasing the switch.

APPLICATION SAMPLE

Attention: Because LINE IN' R channel does not provide the power output, the signal should connect to LINE IN's L channel when connecting few pieces speakers.

1. Stereo model. (long distance)

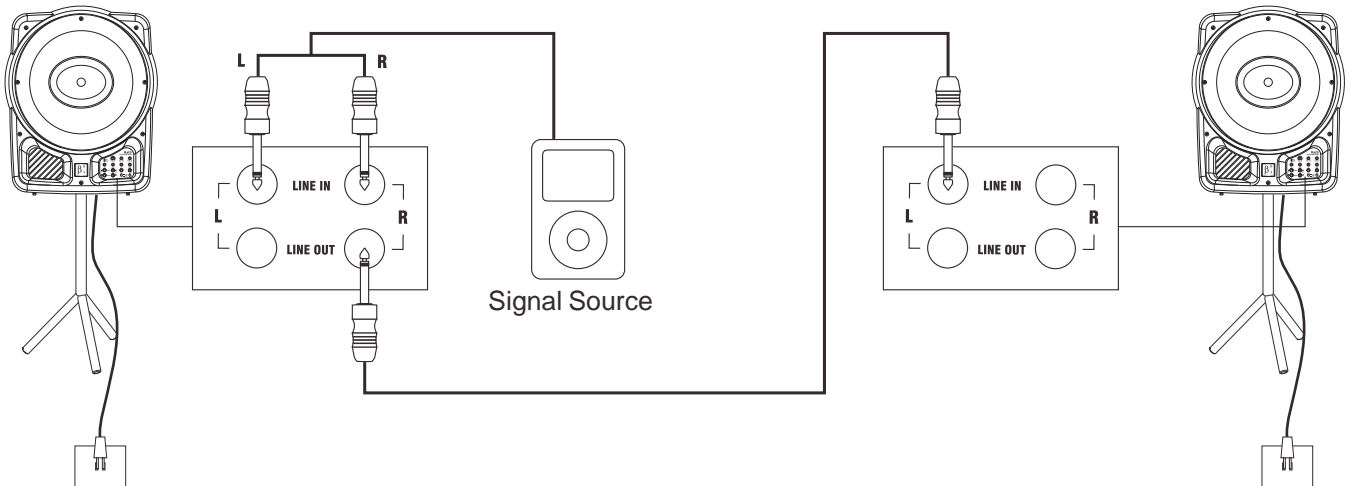

2 Stereo mode II. (short distance)

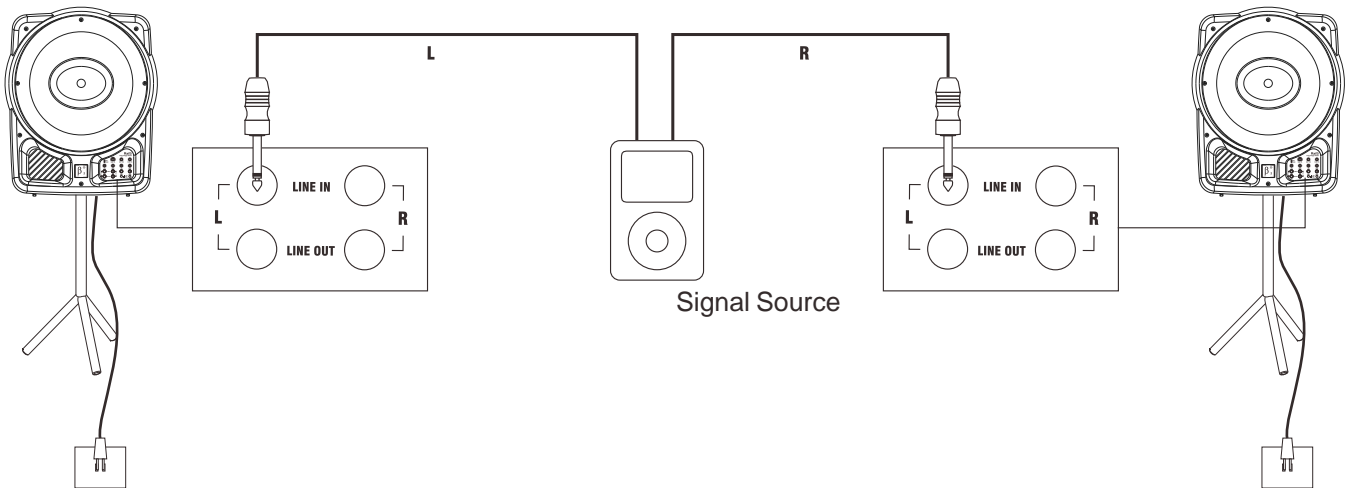

APPLICATION SAMPLE

3. Stereo+Mic (one)

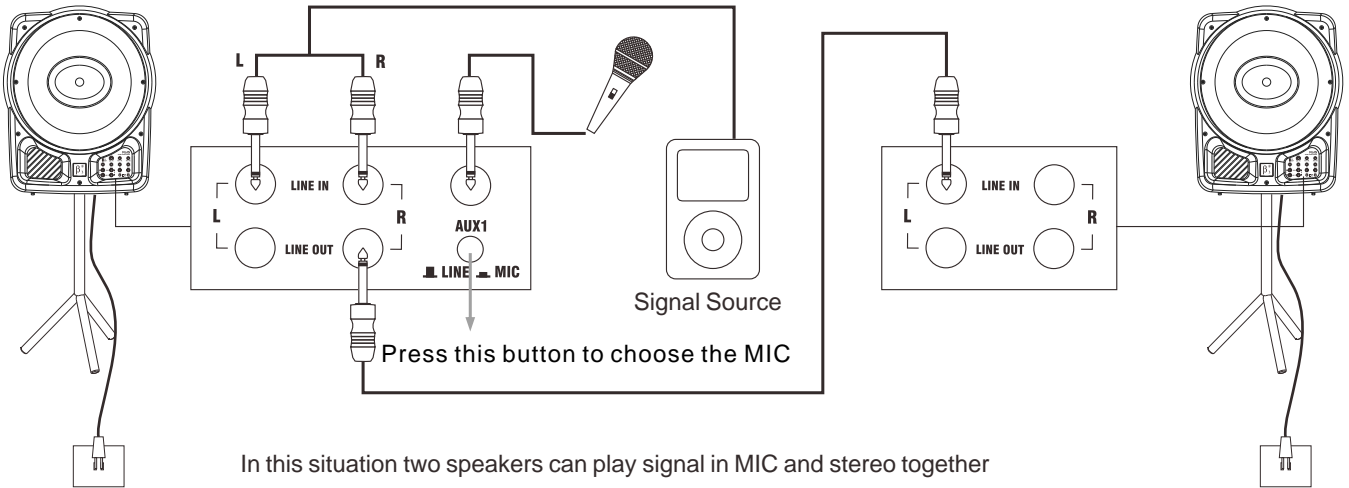

4. Stereo+Mic(two)

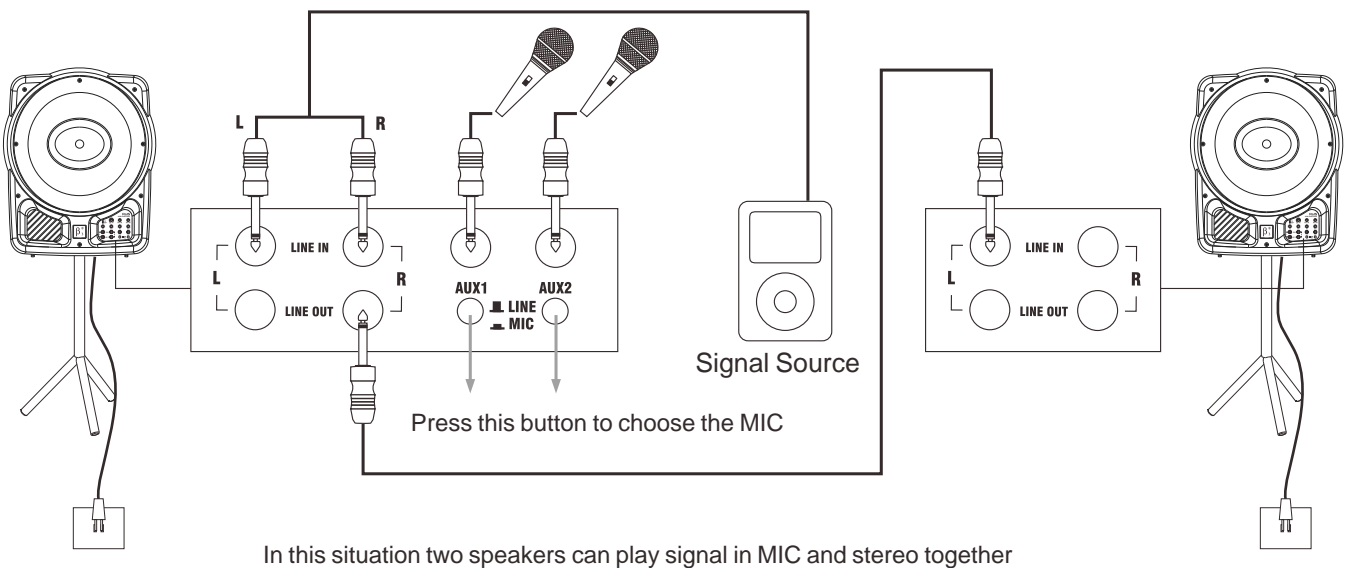

FREQUENCY RESPONSE

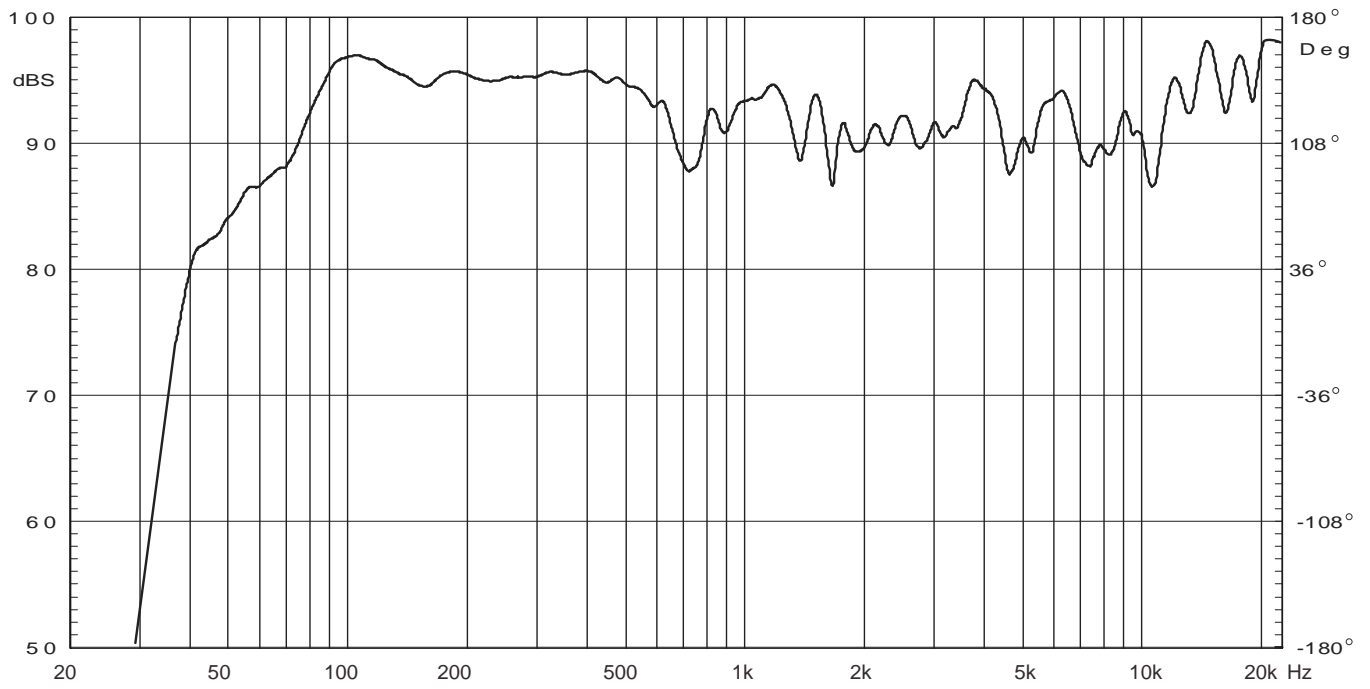

PHASE RESPONSE

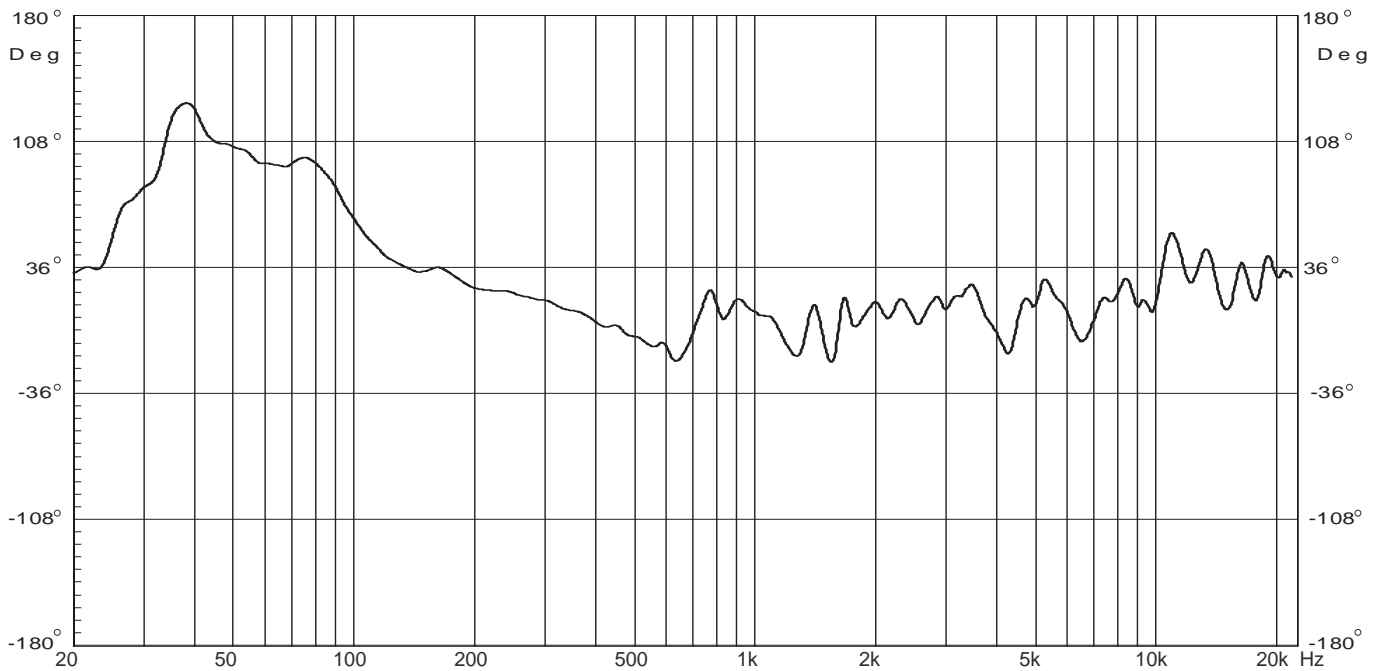

WATERFALL

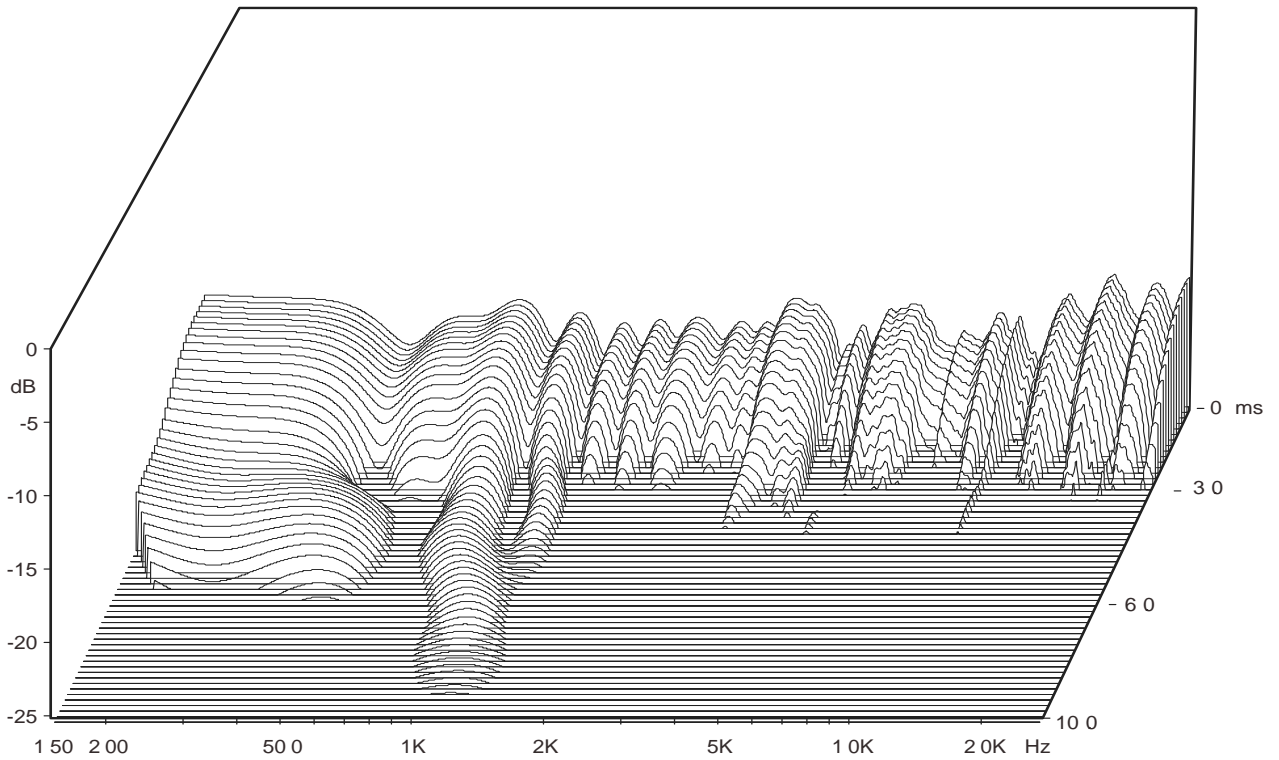

THD

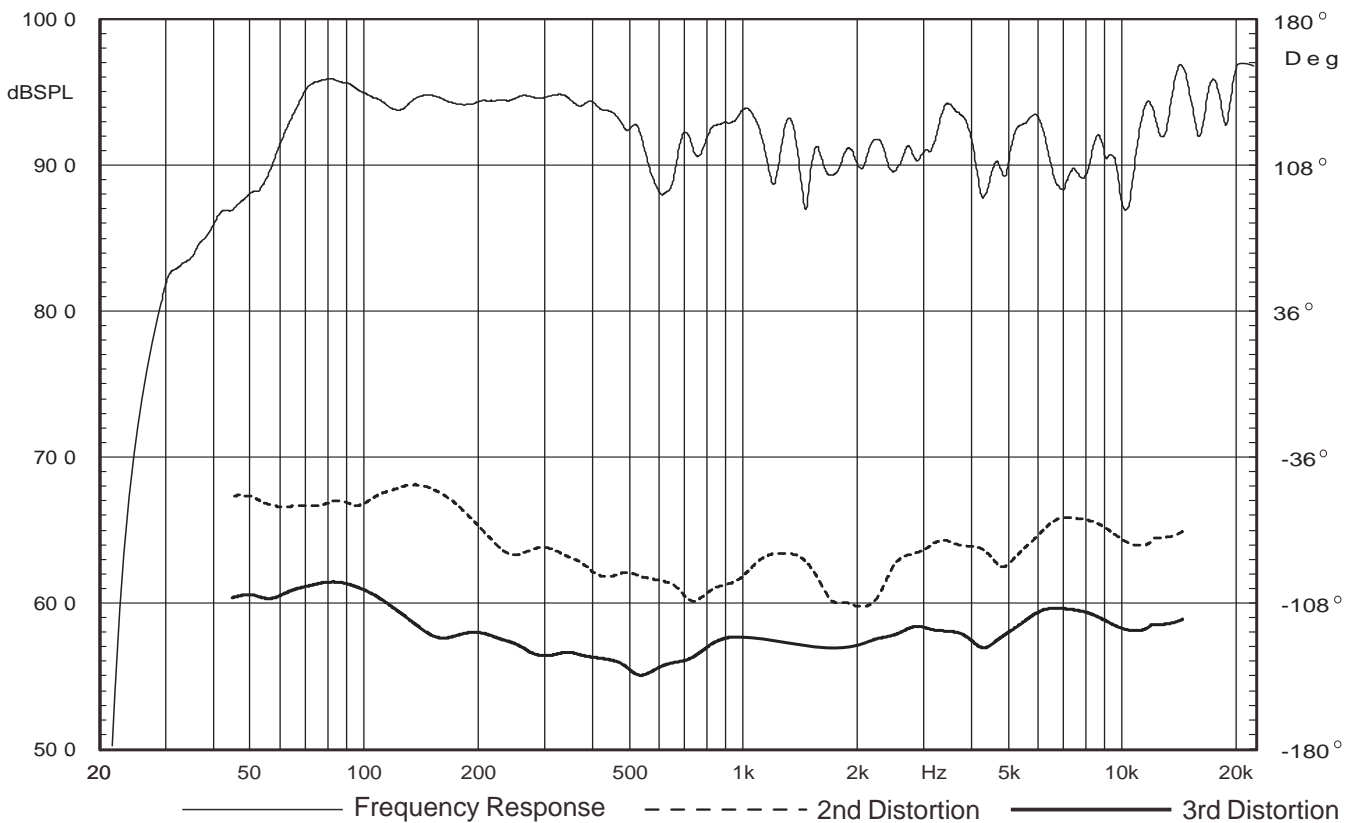

HORIZONTAL DIRECTIVITY

The data of Ra15 horizontal directivity were collected by testing the speaker system in a big anechoic chamber.

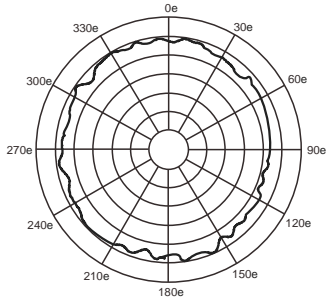

100Hz

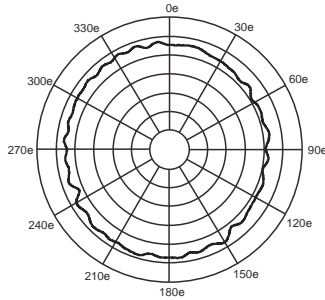

160Hz

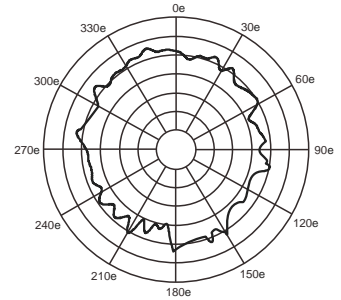

200Hz

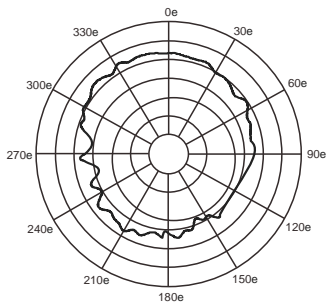

400Hz

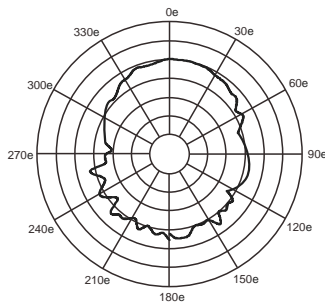

630Hz

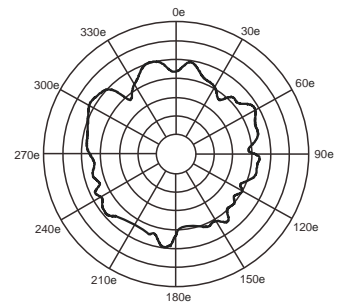

1 0kHz

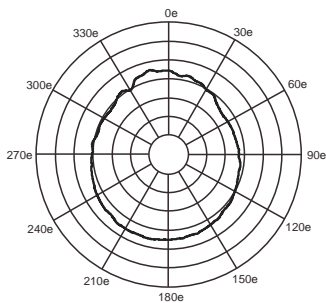

1 6kHz

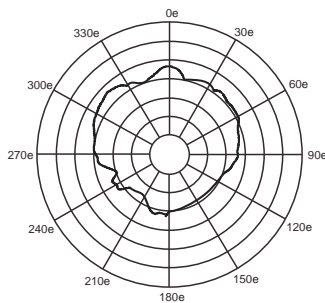

2 5kHz

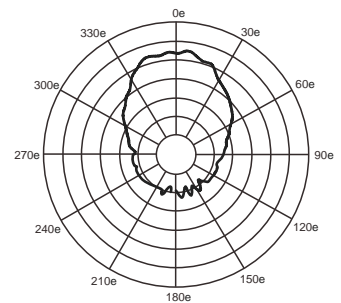

3 15kHz

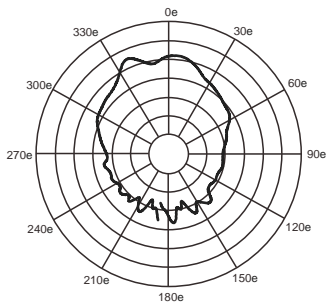

6 3kHz

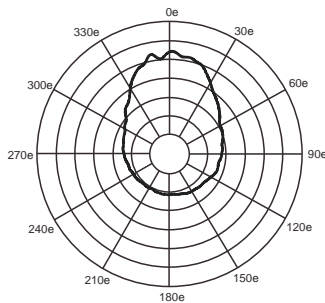

10kHz

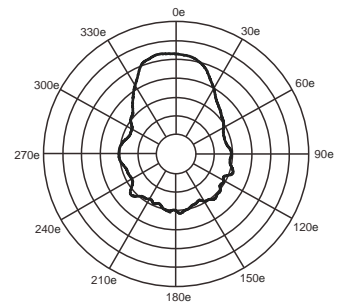

16kHz

The scale is stepped by 6dB increment

VERTICAL DIRECTIVITY

The data of Ra15 vertical directivity were collected by testing the speaker system in a big anechoic

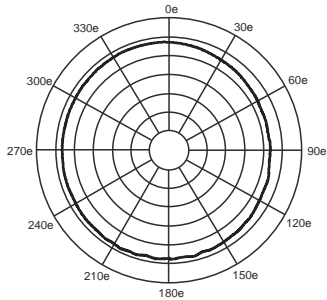

100Hz

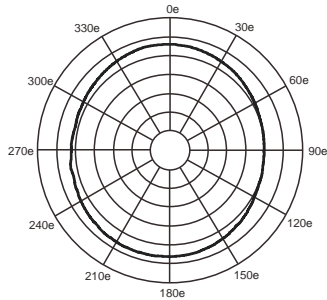

160Hz

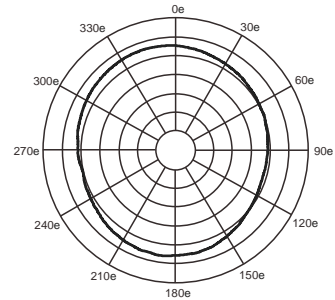

200Hz

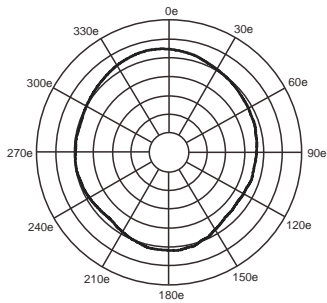

400Hz

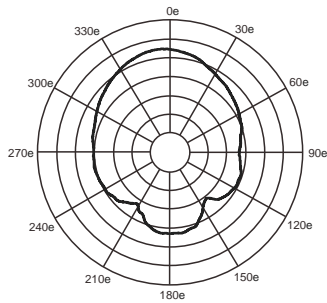

630Hz

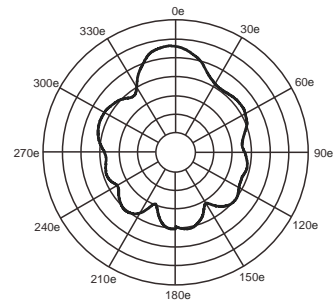

1 0kHz

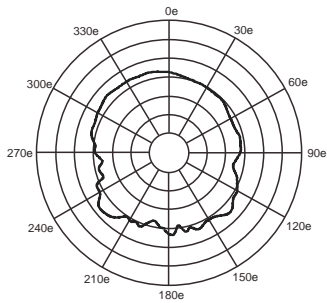

1 6kHz

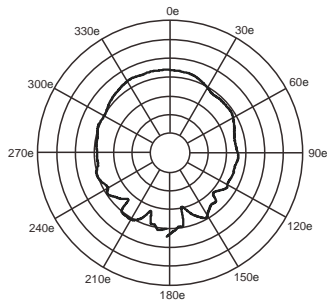

2 5kHz

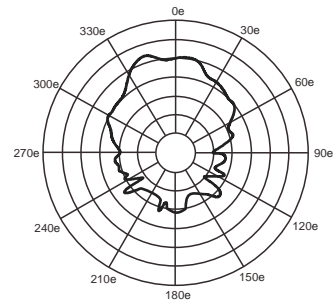

3 15kHz

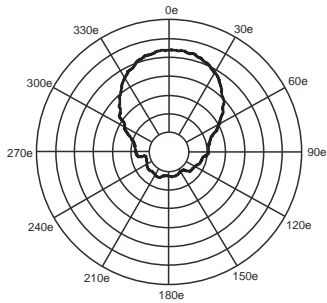

6 3kHz

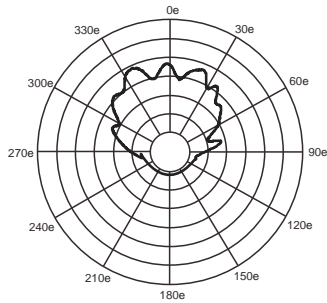

10kHz

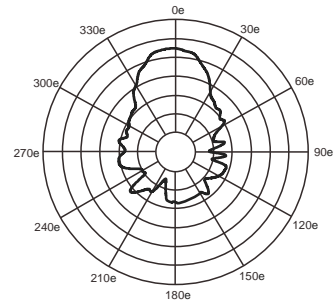

16kHz

The scale is stepped by 6dB increment.

Ra15

INSTALLATION

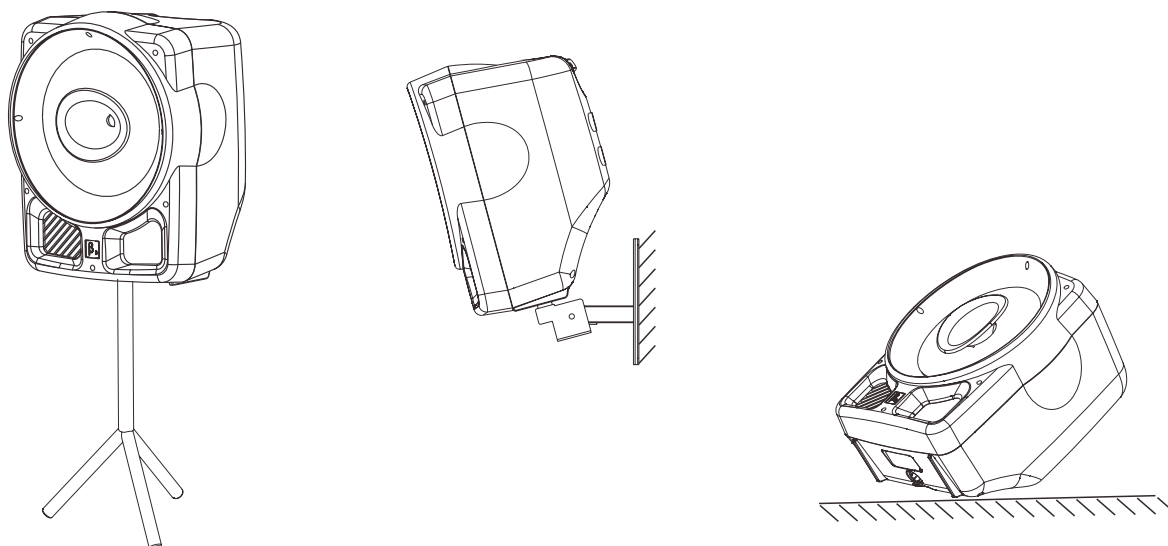

DIMENSIONS

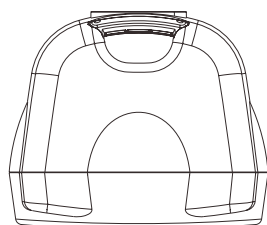

Side view

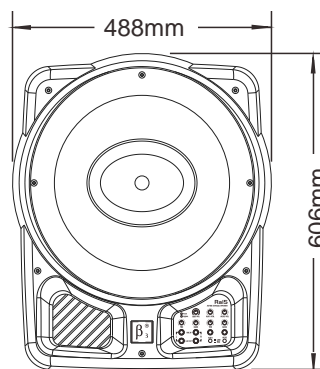

Front view

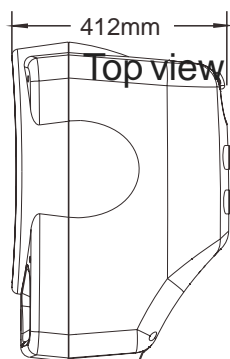

Top view

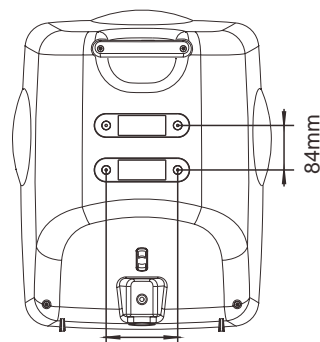

Back view

SAFETY INSTRUCTIONS

DO NOT OPEN THE COVER

Do not open the cover to avoid the risk of electric shock caused by high voltage parts in the product. Any problems caused by user's wrong actions are out of warranty.

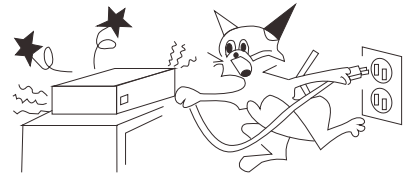

DO NOT DAMAGE THE POWER CORD

Please hold the plug when pull out or plug in the cord. Do not pull out or touch the cord with wet hand. or it will cause the risk of electric shock. Power supply cords should be routed so they are not likely to be walked upon or pinched by items placed on or against them. When removing the cord from a power outlet be sure to remove it by holding the plug attachment and not by pulling on the cord.

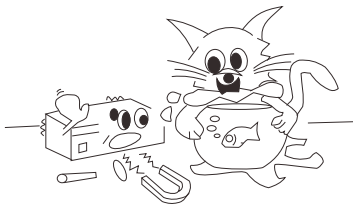

AVOID OBJECT AND LIQUID ENTRY

Take care that objects do not fall into and that liquids are not spilled into the inside of the product. If the object or liquid enter the product, please ask qualified personnel to check it.

ABNORMAL STATUS

In the event of abnormal noise and smell, please put off the power supply and pull out the cord, please ask qualified personnel to check it,

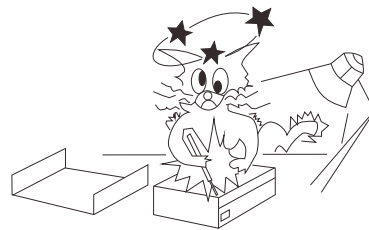

NONUSE FOR A LONG TIME

When nonuse it for a long time, please put off the power supply and pull out the cord to avoid the unexpected dangers.

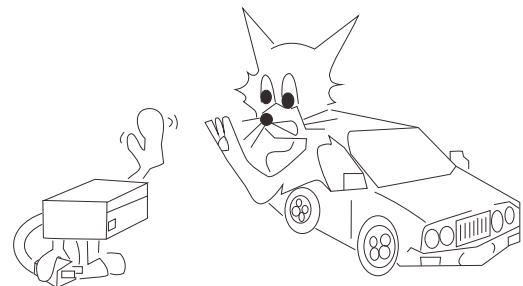

LIMITED WARRANTY

If malfunction occurs during the specified warranty period from the date of original purchase, the product will be repaired or replaced without charge by Elder Audio.

The Limited Warranty does not apply to:

- (a) exterior finish or appearance:
- (b) certain specific items described in the individual product data sheet or owner's manual:
- (c) malfunction resulting from use or operation of the product other than as specified in the individual product data sheet or owner's manual;
- (d) malfunction resulting from misuse or abuse of the product:
- (e) malfunction occurring at any time after repairs have been made to the product by anyone other than Elder Audio Service or any of its authorized service representatives.

To obtain warranty service, customer must deliver proof of purchase of the product in the form of a bill of sale or receipt invoice.

Ra15 Speakers and Speaker Systems are guaranteed against malfunction due to defects in materials or workmanship for a period of three (3) years from the date of original purchase. The Limited Warranty does not apply to burned voice coils or malfunctions such as cone and/or coil damage resulting from improperly designed enclosures. Additional details are included in the Limited Warranty statement.

Ra15 Accessories are guaranteed against malfunction due to defects in materials or workmanship for a period of one (1) year from the date of original purchase. Additional details are included in the Limited Warranty statement.

Ra15 Flying Hardware (including enclosure mounted hardware and rigging accessories) is guaranteed against malfunction due to defects in materials or workmanship for a period of one (1) year from the date of original purchase. Additional details are included in the Limited Warranty statement.

Specifications are subject to change without notice .



Beta Three



Beta Three

Ra15