



ΣC2402

DIGITAL SPEAKER CONTROLLER



TABLE OF CONTENTS

- 1. CAUTION 1
- 2. INTRODUCTION
 - 2.1 Audio Features 2
 - 2.2 User Interface 2
 - 2.3 Other Character 2
- 3. UNPACKING 2
- 4. AC POWER REQUIREMENTS 2
- 5. FRONT PANEL CONTROL FEATURES 3
- 6. INTERCONNECT FEATURES 4
- 7. .DISPLAYS AND OPERATION
 - 7.1 Gain 5
 - 7.2 Source 5
 - 7.3 Polarity 5
 - 7.4 Peq 6
 - 7.5 Crossover 6
 - 7.6 Limit 7
 - 7.7 Delay 7
 - 7.8 Mute 7
 - 7.9 Copy 8
 - 7.10 Recall 8
 - 7.11 Store 8
 - 7.12 Other Tools 9
- 8. TROUBLESHOOTING 10
- 9. SPECIFICATIONS 11
- 10. BLOCK DIAGRAM 12
- 11. INSTALLTION DIMENSIONS 12

1. CAUTION

Instruction:



The lightning flash with arrowhead symbol within the equilateral triangle is intended to alert the user to the presence of un-insulated “ dangerous voltage ” within the product’s enclosure that may be of sufficient magnitude to constitute a risk of electric shock.
The exclamation point within the equilateral triangle is intended to alert the user to the presence of important operation and maintenance (servicing) instructions in the literature accompanying this appliance.

Do not open the cover :



Do not open the cover to avoid the risk of electric shock caused by high voltage parts in the product. Any problems caused by user's wrong actions are out of warranty.

Do not damage the cord :



the cord Please hold the plug when pulling out or plug in the cord. Do not pull out or touch the cord with wet hand, or it will cause the risk of electric shock. Power supply cords should be routed so that they are not likely to be walked upon or pinched by items placed on or against them. When removing the cord from a power outlet be sure to remove it by holding the plug attachment and not by pulling on the cord.

Avoid object and liquid entry :

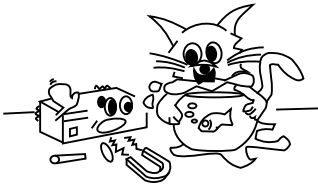

Take care that objects do not fall into and that liquids are not spilled into the inside of the product. If the object or liquid enter the product, please ask qualified personnel to check it.

Abnormal status :

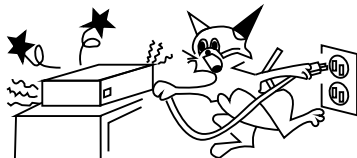

In the event of abnormal noise and smell, please put off the power supply and pull out the cord, please ask qualified personnel to check it.

Nonuse for a long time :

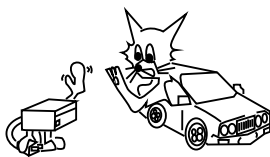

When nonuse it for a long time, please put off the power supply and pull out the cord to avoid the unexpected dangers.

2. INTRODUCTION

Thank you very much for the purchasing of C2402 digital speaker controller whose brand is 3 from Elder company. The product have cohered Elder company's more than ten years' cherish experience in the field of professional audio system. The excellent voice performance and the competitive operate to price will guarantee your profit from your investment.

C2402 provide digital process to the two way analogue input voice signal and the function of frequency process and speaker management. It is very suitable for the improvement of the sound reinforcement in the middle small place. The function key's laying are reasonable and the display is simple and look-easy. It is very convenient for the system test.

2.1 Audio Features

C2402 get the sample at 48Khz, the distinguish rate is the famous 24's - A/D and D/A switch technology, messenger's handling take the high capability 32 DSP and filter. The digital processor include the gain controller, polarity, PEQ(peak, slope, limit and band pass), delay, crossover(the types are Butter worth/Bessel/Linkwitz, the slope rate are 12dB-36dB) limit. All the input and output connector take the precise electronic equalization and RF protect circuit an the standard socket is reliable.

2.2 User Interface

the panel include the signal peak indicator with LED input, user process information with LCD display. The operate key include input, output, and frequency module function adjustment.

2.3 Other Character

have 20 collocated process for user's edition, save and using. for user's digital safty system lock, LCD compare adjustment.

3. UNPACKING

Each product have to be packed carefully before ex warehouse as part of our quality system control. Pleas check carefully on the product's appearance. To the future's convenience of transport and guarantee the product safty and capability, please keep all the packing material. And please notice the distributor immediately in the convenience of provide the letter guarantee if find the appearance damage on the product.

4. AC POWER REQUIREMENTS

Please confirm the local voltage is same with input identification on the AC socket or being included within the range before connect this machine to the local power. The machine have fuse inside, and general speaking the fuse is damaged if the machine fail to connect the power, in this situation please contact with our professional repair person to change another new one same as the fuse type.

5. FRONT PANEL CONTROL FEATURES

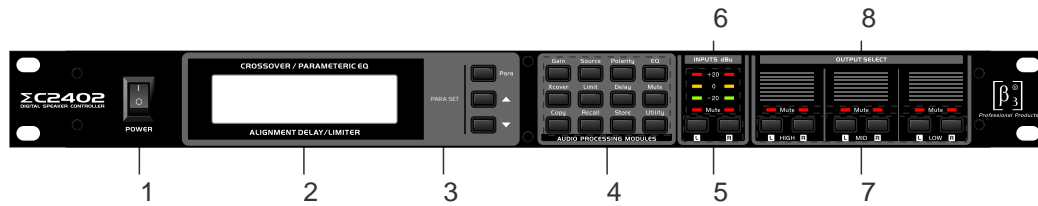

- 1. Power switch:** put the 1 means open and 0 means close
- 2. LCD display:** display the operate situation, e.g. the channel's module's set for the digit
- 3. Parameter set:** choose the parameter need to be adjusted and set the +/- key when the Para Is more than two
- 4. Function key and assistant key on the module:**
 - Gain:** input/output channel signal gain control
 - Source:** choose the voice source on the output channel(only for the woofer)
 - Polarity:** choose the signal polarity on the output channel
 - EQ:** input/output channel parameter realization
 - Xover:** output channel crossover
 - Limit:** output channel signal limit
 - Delay:** input/output channel signal delay
 - Mute:** input/output signal mute
 - Copy:** the copy for the channel or the same parameter(only for the same group channel)
 - Recall:** process's adjustment
 - Store:** process's saving
 - Utility:** assistant function including the system lock switch and LCD contrast
- 5. Input channel's choose:** choose the related input channel under the module for function of L/R
- 6. Input channel signal indicator:** peak indicator, -20db(green), +15db(yellow), +20db(red)
- 7. Output channel choose key:** L-High-R, L-Mid-R, L-Low-R, under the function module, choose the related key to adjust the related output channel
- 8. Channel mute indicator:** on means output mute, off means normal output

6. INTERCONNECT FEATURES

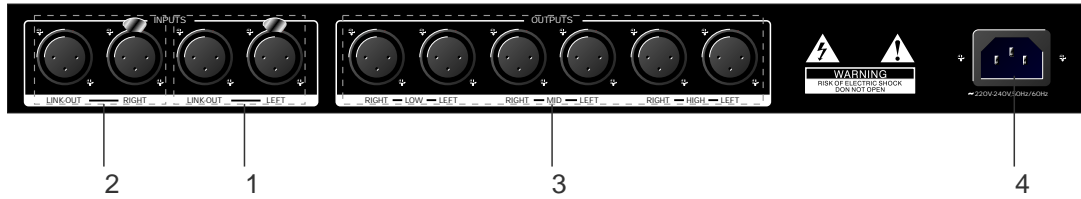

1. L(Left) channel audio input socket and link-out socket
2. R(Right) channel audio input socket and link-out socket
3. L/R channel high, mid, low frequency signal output, total 6chs, usually config as 3XCrossOver of stereo
4. Power input socket, connect to local AC power supply Net.

7. DISPLAYS AND OPERATION

Power on the device and it will display the current Program number and name like following picture:



7.1 Gain

Press the Gain key and enter into the gain control interface like the picture:

Input and output gain can be adjusted separately, the range is -40db,+12db,the precise is 0.5dB.

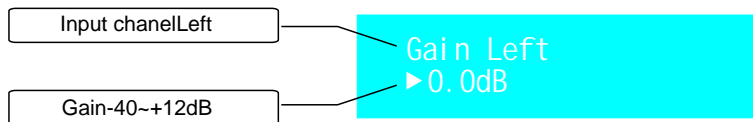

Press the channel choose key and choose the related channel need to be adjusted, put the +/- key to adjust the gain electric frequency.

Parameter set key:

Use Para key to choose the parameter need to be adjusted (Only available for more than one Parameter).

+/- key is for changing present Para value

(Remark: " ▶" is flash symbol, if there are several Para in one function can be adjusted, please press the para key on the panel to move the flash to correspondent para position.)

7.2 Source

Press the source key and enter into the source choose interface like the below picture:

Only two woofer channels L-Low-R can choose the source which is Left, Right, and Left Right.

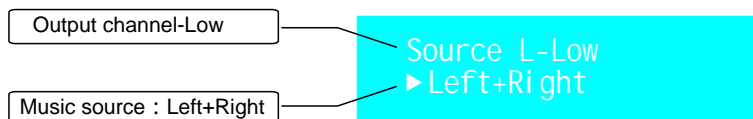

Press the channel choose key and choose the related channel need to be adjusted, put the +/- key to choose the source.

7.3 Signal Polarity

Press the polarity key to enter into the signal polarity adjustment channel, like the below picture:

Only the output channel signal polarity can be adjusted and the range is Normal and Reverse.

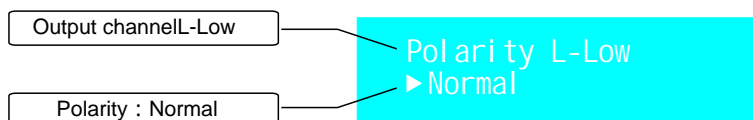

Press the channel choose key and choose the related channel need to be adjusted, put the +/- key to adjust the signal polarity.

7. DISPLAYS AND OPERATION

7.4 PEQ

Press the EQ key to enter into the adjust interface of output PEQ as the below picture:

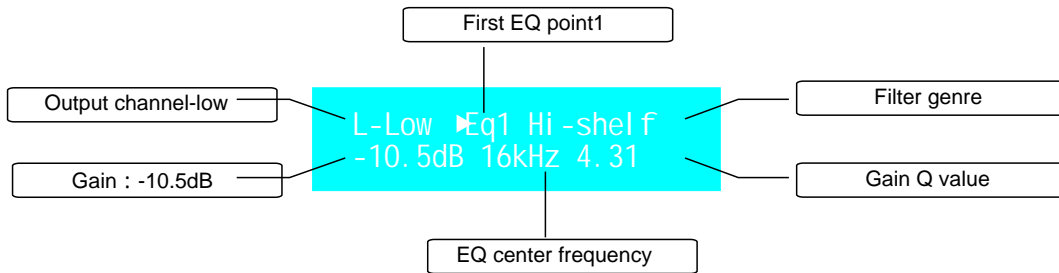

Press the channel choose key and choose the related channel need to be adjusted and press the Para key to choose the parameter which can be changed by the key of +/-.

There are 4 PEQ point in each input channel and 6 in the output channel.

The filter's type : OFF, Peaking, Notch, Hi-shelf, Loshelf, Band pass and their function is describe as below:

Peaking: it is the peak filter which in most of the time to be used to modify the voice system's frequency curve and voice tamber.

Hi-Shelf: it is the treble filter and used as the treble's raise and lower

Lo-Shelf: it is the woofer filter and used as woofer's raise and lower

Band pass: it is band pass filter, not used frequently besides the special requirement of bandpass

Notch: it is limit filter mainly for the limit of fix howling for the reason of sound reinforcement's lack.

The filter gain's adjustment range is 12Db+12.0db and the precise is 0.5db;

The centre frequency is as per the 1/12oct and totally 121 frequency point can be choosed, the Q number is the filter quality factor.

7.5 Crossover

Press the crossover key to enter into the adjust interface of the output channel signal HPF and LPF as the below picture.

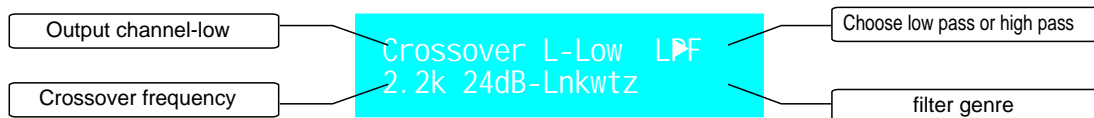

Press the channel selection key and choose the related channel need to be adjusted and press the Para key to choose the parameter which changed by the key +/-

Each output channel include one HPF and LPF filter, and the below is their types:

12dB/oct Butterworth, 24dB/oct Butterworth, 36/oct Butterworth,

12dB/oct Bessel, 24dB /oct Bessel, 36db /oct Bessel

12dB/oct Linkwtz, 24 dB/oct Linkwtz

Crossover point frequency has 121 points available for choice based on 1/12 oct.

7. DISPLAYS AND OPERATION

7.6 Limitations

When pressing " Limit " button, you will enter the adjusted screen of limitation function of output signal, see the following:

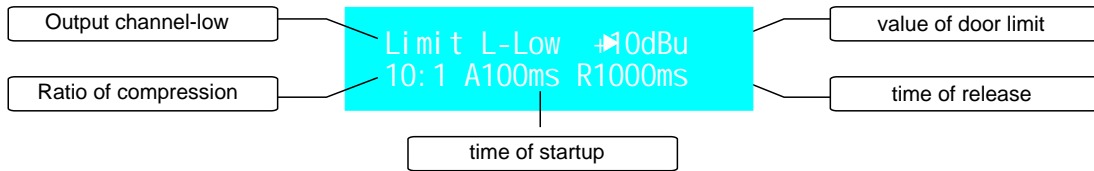

Press channel, choose corresponding adjustable channel, and press Para button and then choose parameter, +/- to change the parameter value.

The limitation range is:-20dBu--+20dBu

Compression ratio range: 1:1~INF:1, 1:1 expresses direct channel for limitation equipment, 1NF expresses limitation equipment.

Range of starting time: 0.010ms ~820ms

Range of releasing time: 100ms ~4700ms

7.7 Delay

Press " Delay " and enter input, output channel signal delays the adjusted screen, see the following:

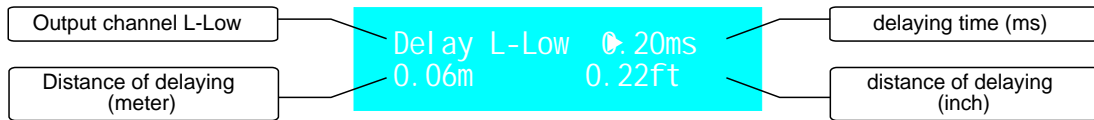

All the channels of this equipment share the delaying line, therefore we can distribute the delaying time dynamically, every channel can delay at most 40ms.

Press " Chooses " , choose corresponding adjustable channel, and press +/- to adjust time of signal delaying, at the same time, use " meter " and " inch " as the delaying distance.

7.8 Mute

Press " Mute " and then enter input, the mute screen of output channel signal, see the following:



Repress " Mute " , all the channels are mute, press the choosing channel and then control corresponding mute of the channel to open or close.

7. DISPLAYS AND OPERATION

7.9 Copy

Press " copy " and enter the screen of parameter copy, and then copy the present parameter to another channel, see the following:

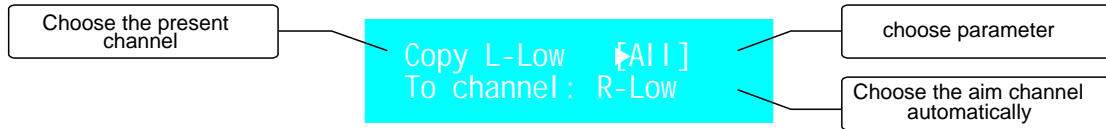

Press the choosing channel to choose the present channel,(the aim channel will choose another channel in one group) ,press +/-to choose the copy parameter ,after choosing, repress copy button to confirm the copy one.

- Parameter range: ALL---copy all the parameter of the present channel;
- EQ---copy the parameter balanced setting of the channel;
- XOVER---copy the setting of crossover of the present channel;
- Gain---copy the gain setting of the present channel;
- Limit---copy limitation setting of the present channel;
- Delay---copy the delaying setting of the present channel.

7.10 Recall Program

Press " Recall " and enter the recall screen of previous program (if using the present channel, just give up the present edited parameter, and then recover the original setting), see the following:

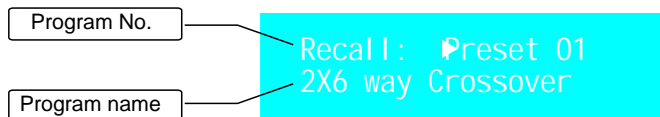

Press +/-to choose the adjustable program, and then press " Recall " to confirm recall.

7.11 Store Program

Press " Store " and enter the protecting screen of previous program, we can keep the present program or put the present program into different program No. or program name. See the following:



Press Para to choose present parameter ---program No., press +/- to store new program No. ; Press Para to choose present parameter---program name, press +/- to enter program name, press Para pad
After finishing setting, repress store and confirm storing.

7. DISPLAYS AND OPERATION

7.12 Other Tooling

Press utility to enter the setting screen of assistant function, we can set the plate lock and contrast, see the following:

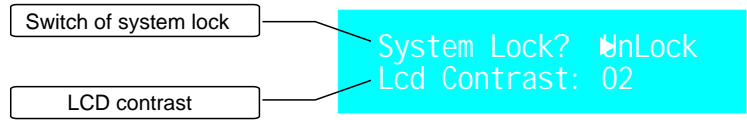

Press Para to choose LCD contrast, and press +/- to adjust contrast, we can choose 00(weak), 01(normal), 02(strong).

Press Para to choose plate lock for the setting of switch, press+/-, and transfer unlock/lock, lock here means the plate lock is effective, expect mute and utility ,other ones we can not edit ,off means all the functions can be operated on the boards.

8. TROUBLESHOOTING

Problem	Check And Solution
Cannot POWER ON	Whether power cable connect to power supply net, or the switch not press down
Parts of key on panel cannot operation	Key lock function enable or not?
No signal output or is very small	Whether input, output are in the condition of mute? Whether input, output gain decay overabundance? Whether input, output signal route is correct? If setting crossover ,whether HPF corner frequency is lower than the LPF corner frequency?
Overload light is often on	Lower the input signal, the biggest input is +20dbu
Sound faulty, some frequency is lost	If you want to input full way signal, please check whether crossover is open and lead to cut off or lower down some frequency ?
Over white noise	Please check whether the input gain is too small, but output gain is too much?
Contrast of screen is in deviation	As the temperature features of lcd, when the temperature is too high or too low, the contrast of screen will decrease or increase, please adjust the contrast under utility.
System hum noise	Please check the connection of the system, especially pay attention to the connection to the ground .

9. SPECIFICATIONS

Analog Input:

Input: balance XLR-3-32 input socket
Input Impedance: 10k
Max input level: +20dBu
A/D Converter: 48kHz sample frequency, 24bits linear

Analog Output:

Input: balance XLR-3-32 out put socket
Output Impedance: 100
Load impedance: <600
Max input level: +20dBu

Simulation Sound:

Frequency response: 20Hz~20 kHz (+0.3/-0.3dB), 10Hz~30kHz (+0.3/-3.0dB)
Dynamic range: 110dB(A -Weight)
Total distortion and noise : < 0.006%
Min time of delaying: about 1.2ms (we set the delaying parameter of signal input and output as 0)

Others:

Power requirement: AC 220V-240V~, 50/60Hz
Power consuming: 20W
Dimension(W x D x H): 482 x 172 x 45mm
Weight: 3.0kg
Operation temperature: 0~+40
Storage temperature: -10~+60

Accessories:

Power cable: 1 pcs
The fuse: 250mA@220V AC delaying
User manual: 1pcs

Exterior design and specifications are subject to change without notice

10. BLOCK DIAGRAM

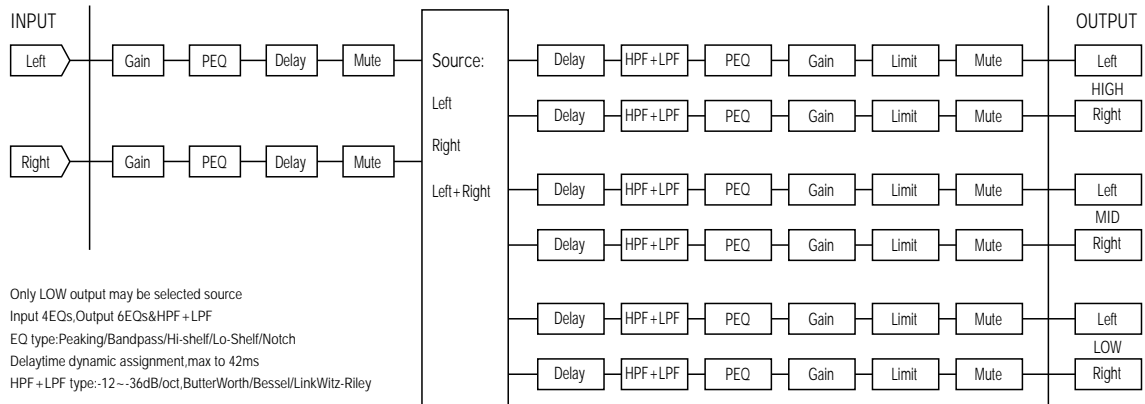

11. INSTALLTION DIMENSIONS





Beta Three

ΣC2402