

Beta Three

TLB-101

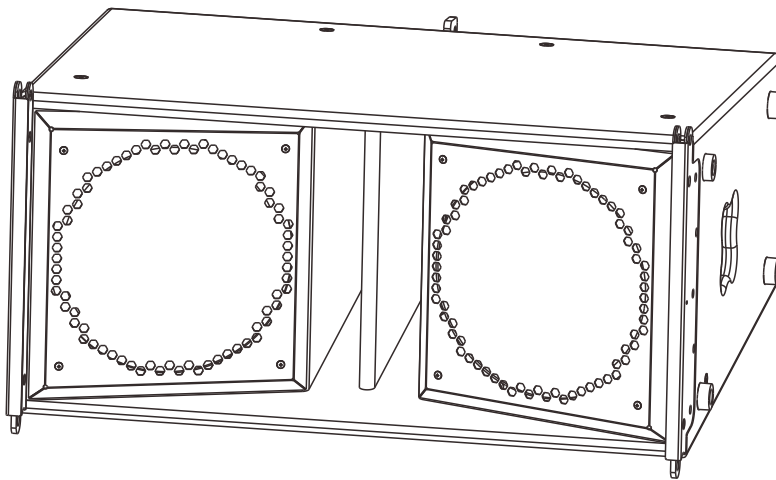



CONTENTS

Product features	-----	1
Specifications	-----	1
Acoustic charts	-----	2
Installation	-----	4
Dimensions	-----	5
Limited warranty	-----	6

TLB-101

FEATURES

TLB-101 is a multifunctional low frequency speaker, can be used with TLA-101 to make up a full range speakers, and also can be separately used as array system.

The adjust angle between TLB-101 and metal flying frame is 5°

The adjust angle between TLA-101 and TLA-101 range is from 0° - 5°

The TLB-101 suited amplifier can be 3 U2000, UA2002 or AP-4U/AM-4U built-in analog/digital control cards

TLB-101 is composed of 2 x 12 inch Neodymium woofers

TLB-101 frequency response range is 50Hz -250Hz

The enclosure is made of birch plywood, with hit-resistance and waterproof finish processing. The front grill is solid metal with well protection, there is a handle on each side of the enclose. Optional accessories are metal flying frame, flying parts and connection parts for TLA-101.

SPECIFICATIONS

Transducers:	LF: 12" x 2
Frequency Response (-3dB):	40Hz-250Hz
Sensitivity (1m/1w):	100dB
Maximum SPL (1m):	129dB/135dB
Power (AES):	800W
Rated impedance:	4
DC Impedance:	2.9
THD:	<5%
Input Connector:	NL4 x 2 1+/1-
Net Weight (pcs):	45.5kg
Gross Weight (pcs):	49.5kg
Net Dimensions (W x H x D) :	800 x 388 x 595mm
Packing Dimensions (W x H x D) :	935 x 815 x 560mm

Note: Power handling is measured under AES standard conditions. transducer driven continuously for two hours with band-limited noise signal having a 6dB peak-average ratio.

TLB-101

FREQUENCY , PHASE RESPONSE

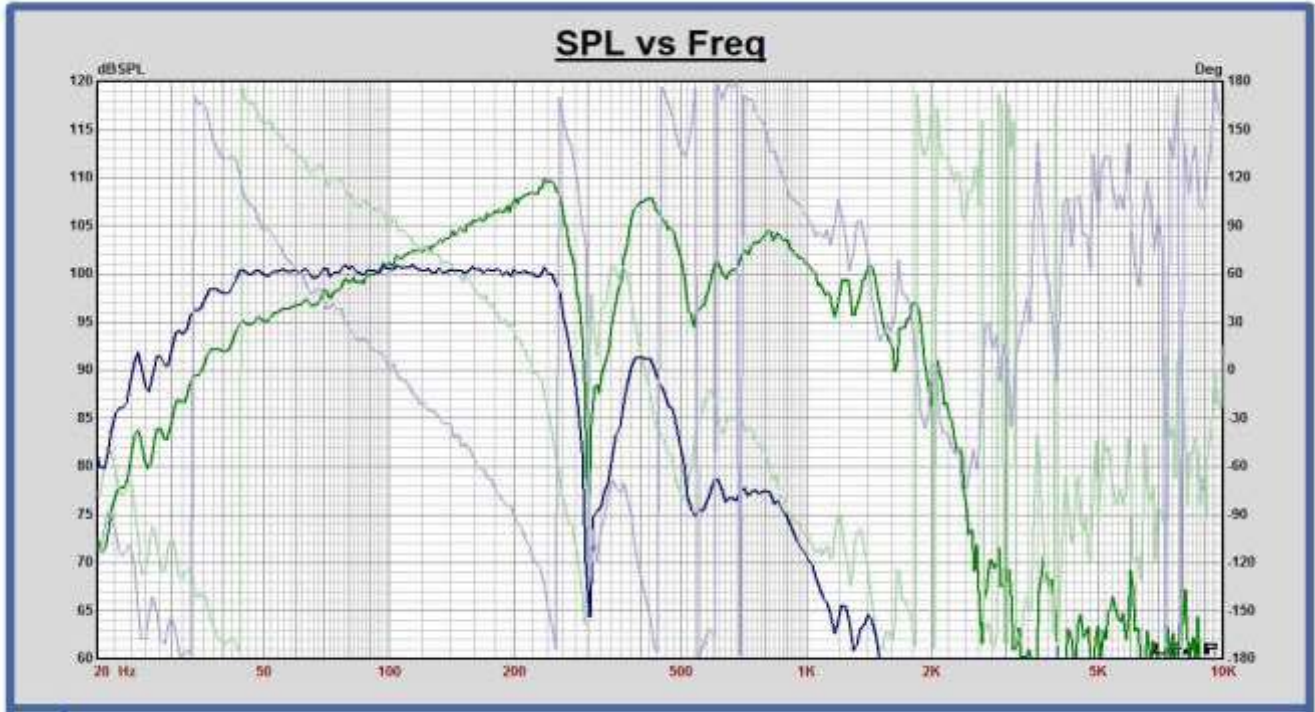

———— PHASE RESPONSE ———— FREQUENCY RESPONSE

IMPEDANCE RESPONSE

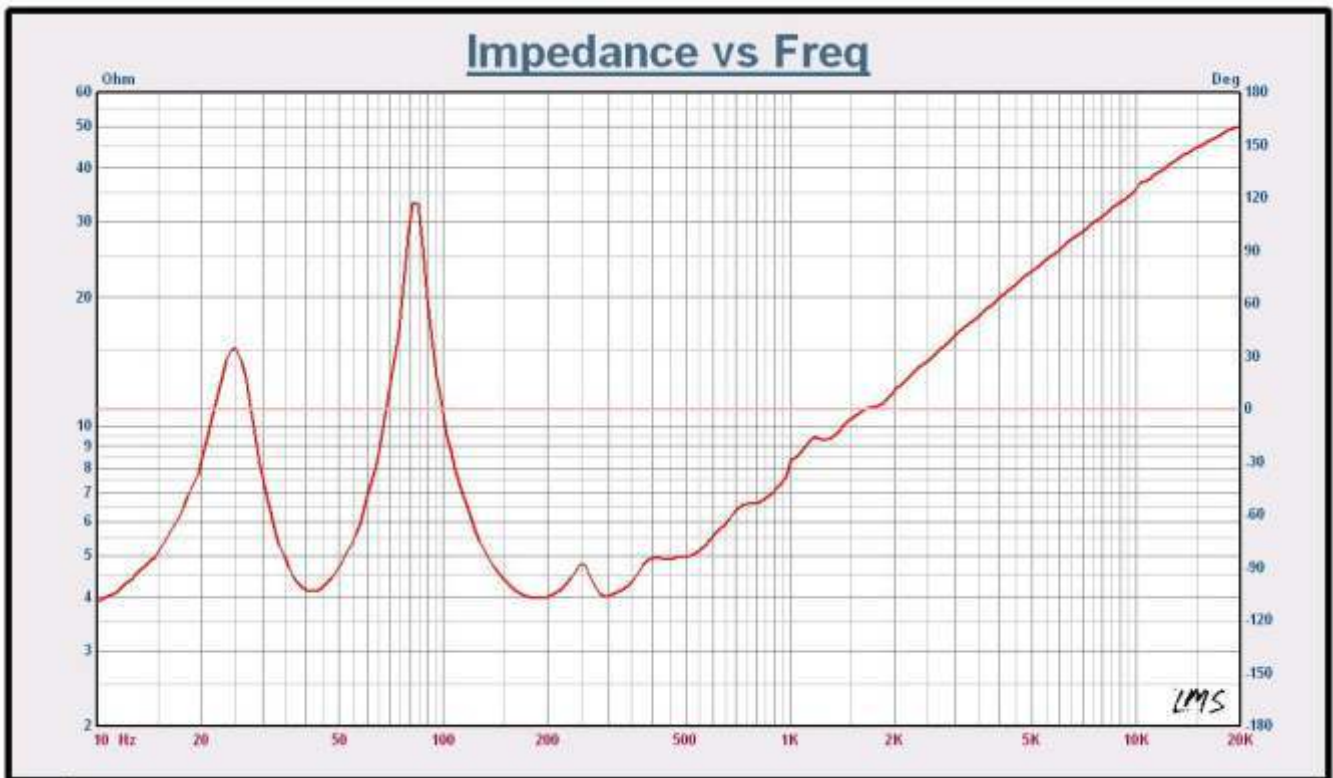

TLB-101

WATERFALL

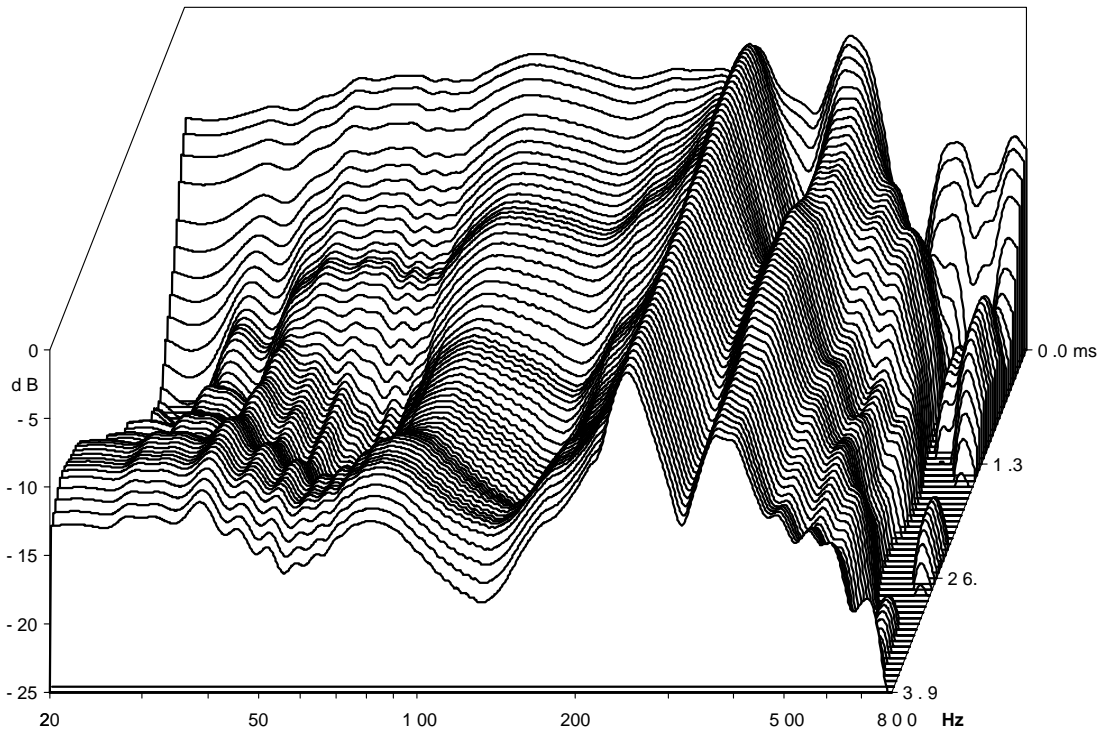

THD

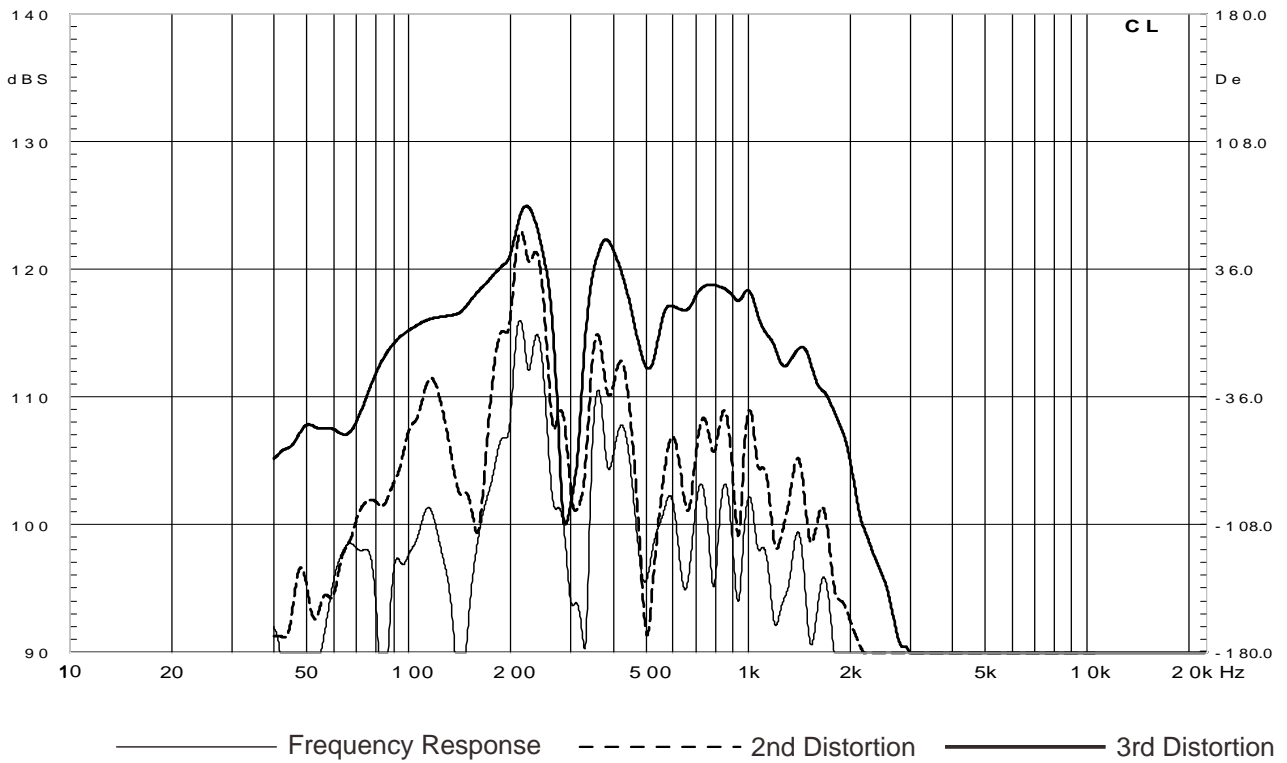

TLB-101

INSTALLATION GUIDANCE

TLB-101 three points (trigonometry) suspension

The flying system includes TLB-101 flying metal frame, front and back rigging parts and pins

Rear rigging part has been assembled onto cabinet to make the vertical angle

(between each unit) adjusting easier and convenient

TLB-101 flying frame is weld steel frame,

can hang up many TLB-101 speakers

The adjust angle between TLB-101

and flying frame grid is 5°

The angle range between each speaker is $0^\circ - 10^\circ$

The angle between TLB-101 and TLA-101

can be adjusted at: $0^\circ - 5^\circ$.

The suspension hole is as drawing:

TLB-101 has four rubber feet on

one side of the enclosure, and it's

available for ground stacking

application. The feet can be

disassembled when it's for flying

avenues (please keep the screws

into the screws hole as it was).

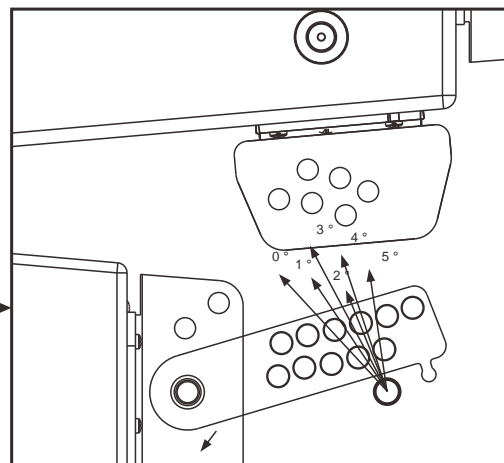
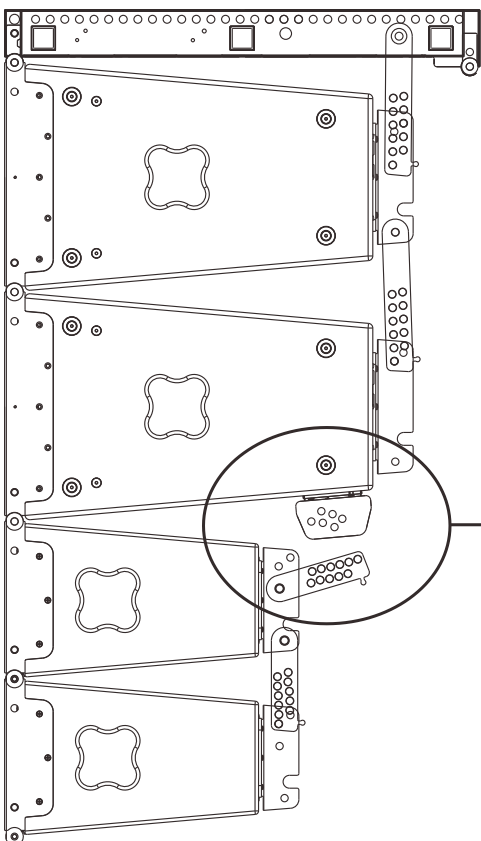
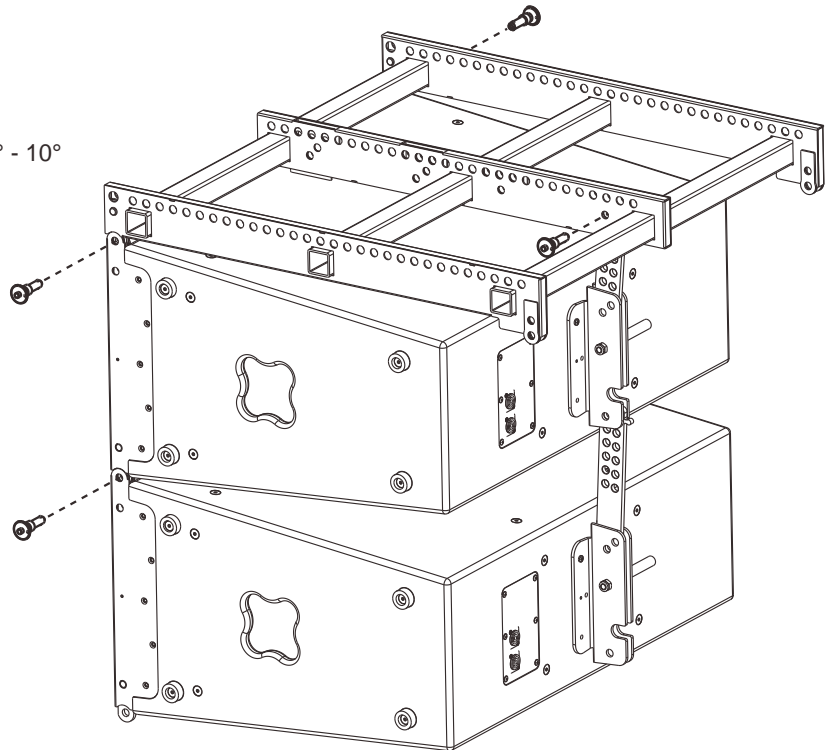

Note: Please ensure the angles adjust panel hole should be matched with relevant hole with degree marks.

TLB-101

DIMENSIONS

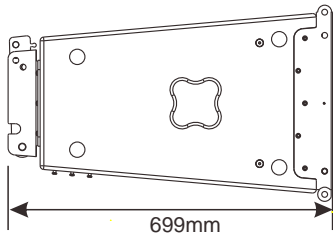

Side view

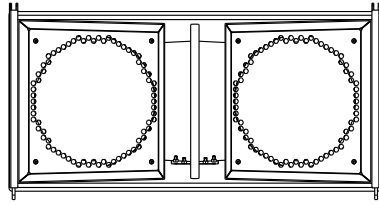

Front view

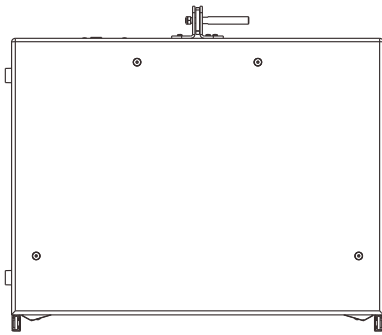

Planform

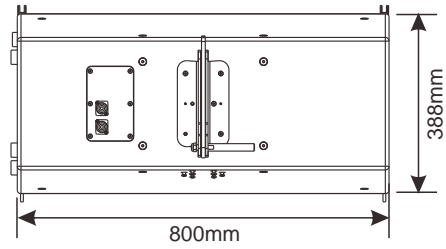

Back view

LIMITED WARRANTY

If malfunction occurs during the specified warranty period from the date of original purchase, the product will be repaired or replaced without charge by Elder Audio.

The Limited Warranty does not apply to:

- (a) exterior finish or appearance;
- (b) certain specific items described in the individual product data sheet or owner's manual;
- (c) malfunction resulting from use or operation of the product other than as specified in the individual product data sheet or owner's manual;
- (d) malfunction resulting from misuse or abuse of the product;
- (e) malfunction occurring at any time after repairs have been made to the product by anyone other than Elder Audio Service or any of its authorized service representatives.

To obtain warranty service, customer must deliver proof of purchase of the product in the form of a bill of sale or receipt invoice.

TLB-101 Speakers and Speaker Systems are guaranteed against malfunction due to defects in materials or workmanship for a period of three (3) years from the date of original purchase. The Limited Warranty does not apply to burned voice coils or malfunctions such as cone and/or coil damage resulting from improperly designed enclosures. Additional details are included in the Limited Warranty statement.

TLB-101 Accessories are guaranteed against malfunction due to defects in materials or workmanship for a period of one (1) year from the date of original purchase. Additional details are included in the Limited Warranty statement.

TLB-101 Flying Hardware (including enclosure-mounted hardware and rigging accessories) is guaranteed against malfunction due to defects in materials or workmanship for a period of one (1) year from the date of original purchase. Additional details are included in the Limited Warranty statement.

Specifications are subject to change without notice.

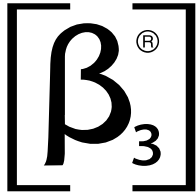

Beta Three

TLB-101